

Installation Procedure for NSC-C1215

(The diagrams shown represent a right-handed opening type. The left-handed opening type is symmetrical with the type represented in these diagrams.)

1 Installing a rail

1) Cutting the rail, making a new mounting hole

- Cut the rail to the inner width of the sash less 150mm.
- Cut off the correct end according to the instructions given on the sticker as follows:
 - For the right-handed opening type, cut off the right end as viewed from the front.
 - For the left-handed opening type, cut off the left end as viewed from the front.

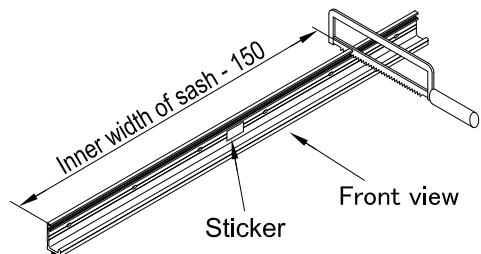

- If the distance between the cutting face of the rail and the reference mounting hole is no less than 80mm, make a new hole $\phi 5.5\text{mm}$ for installing the rail at the position 50mm from the end.

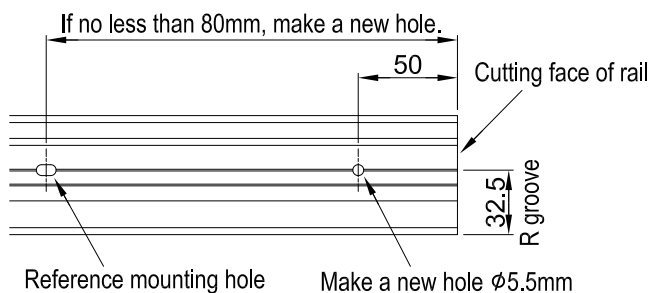

⚠ Caution

- When making any change in the rail, take care not to scratch the runway.

2) Drilling a hole for door stopper

- As shown in the diagram, drilling a hole (2- $\phi 4.5 \sim \phi 5.0\text{mm}$) in end of rail.

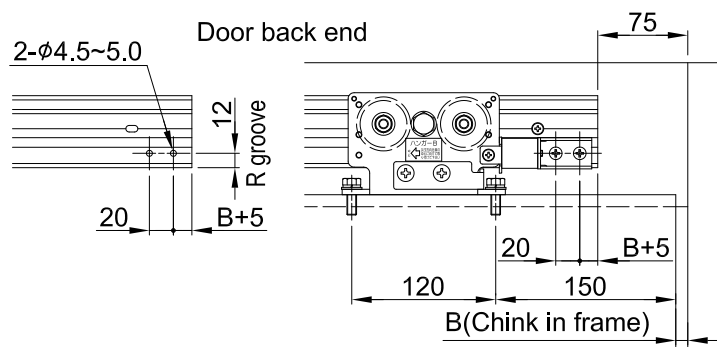

2 Installing the hanger

1) Making holes in the top of the door

- As shown in the diagram, install the hanger A and hanger B.

	Door front end	Door back end
Right-handed opening type	Hanger A side	Hanger B side
Left-handed opening type	Hanger B side	Hanger A side

⚠ Caution

- Install the hanger on the centerline of the door.

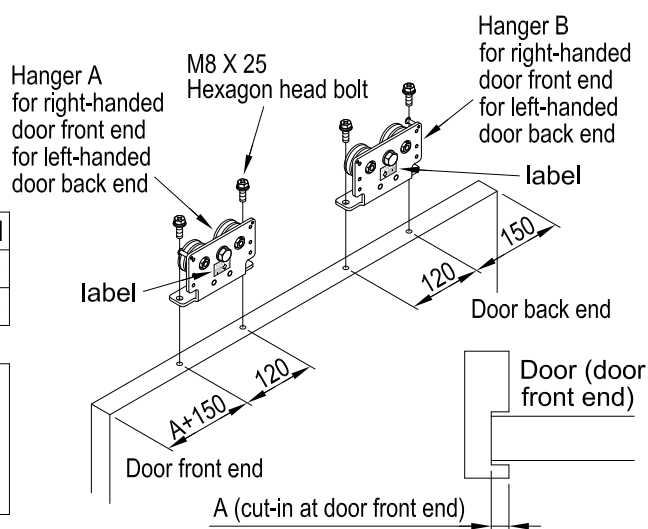
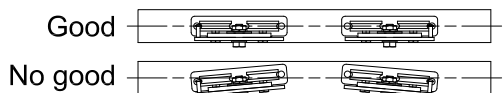

4 Mounting the door

1) Mounting the door

- Before mounting the door, wipe off the dirt from the rail runway.
- Match the door bottom to the guide roller, then suspend the door rollers and mount them onto the rail runway.
- Check that the door operates smoothly.
- Adjust the clearance between the door and jamb by varying the number of height adjusting plates used.

⚠ Caution

- When mounting the door, take care not to scratch the rail runway.
- Be sure to install the control device after mounting the door. When suspending and mounting it, the door may strike and damage the rail and other component.

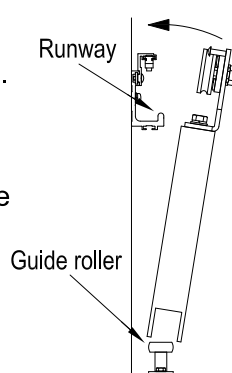

2) Installing the door retaining fitting

- Install the door retaining fitting in the hanger A and B with screw (M8 X 12 pan head screw).

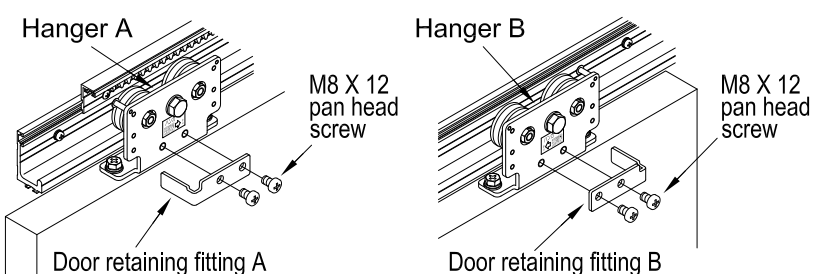

⚠ Caution

- Be sure to install the door retaining fitting, the door may come off.

3) Installing a control rack set

- Insert 2 plate nuts in the T groove in the rail.
- Match the plate nuts to the mounting holes in the control rack set, then install the control rack set with screws (M4 X 8 truss screws) furnished with the product.

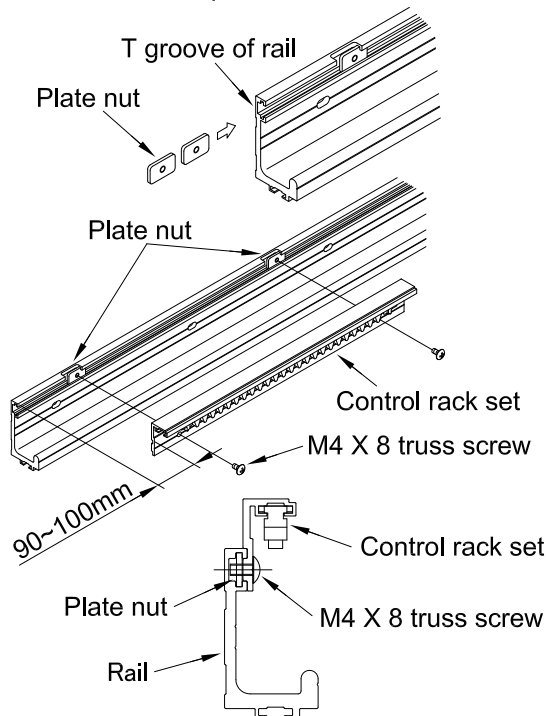

⚠ Caution

- Be sure to use specified screws furnished with the product. Using any unspecified screw may cause it to interfere with the clutch gear of the control device.
- Tighten the screws securely. Otherwise an abnormal noise or imperfect control may result.

4) Setting rail mounting holes

- Tap holes (M5, pitch 0.8) horizontally at intervals of 300 with the hole specified below as the reference point.
 - Dimension from the inside of the sash on the door front end = 125mm
 - Dimension from the bottom of the top frame of the sash = 65mm (When the cover between the top frame and door is 10mm)
- If the dimension A in the diagram below (the dimension from the final hole at a pitch of 300 to the inside of the sash on the door back end) is no less than 155mm, tap a hole at 125mm from the inside of the sash.

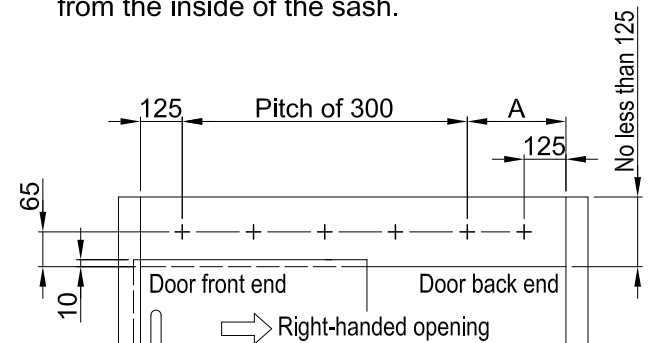

5) Installing the rail

- Install the rail with screws ($\phi 5\text{mm} \times 30$ truss tapping screws or M5 X 16 pan head screws)

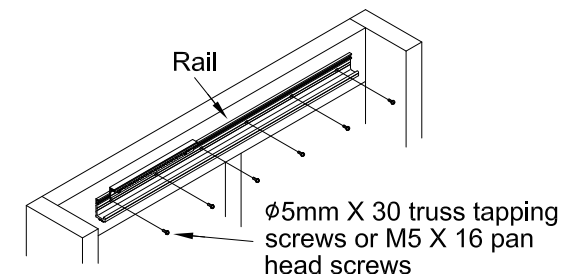

⚠ Caution

- Install the rail horizontally. When installing the rail, take care not to scratch the runway.

3 Installing the guide roller (optional)

- Install the guide roller in the middle of the door lap.
- Install the guide roller so that the door becomes vertical with the floor.
- If floor is concrete or mortar, use the fisher plug (prepared hole 6mm).

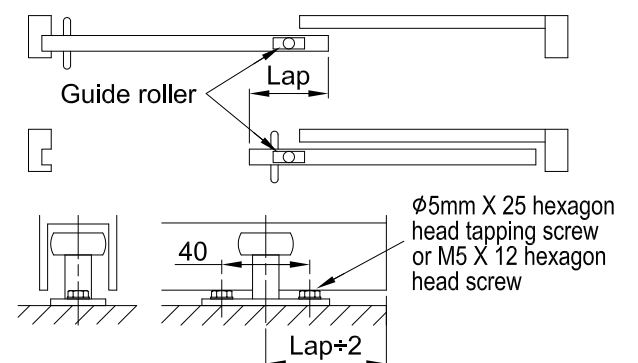

⚠ Caution

- Be sure to use the guide roller.

Installation Procedure for NSC-C1215

5 Installing the door stopper

- Install the door stopper plate on the hanger on the door back end with screws (M5 X 8 pan head screws)
- Install the door stopper in the rail runway.
- See the page 1 , 1 Installing a rail 2) Drilling a hole for door stopper

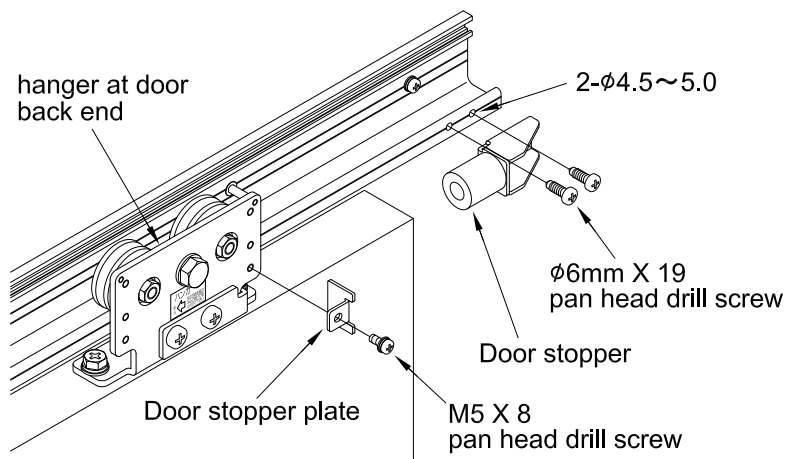

⚠ Caution

- Tighten the screws securely to prevent the door from coming off.

6 Installing the control device

- In assembling and reengaging the clutch gears, follow the "Procedure for assembling and reengaging clutch gears."
- Install the control device on the hanger on the door front end with screws (M5 X 12 pan head screws) furnished with the product. Install it with the door open by at least 60cm (where it does not engage with the control rack set).

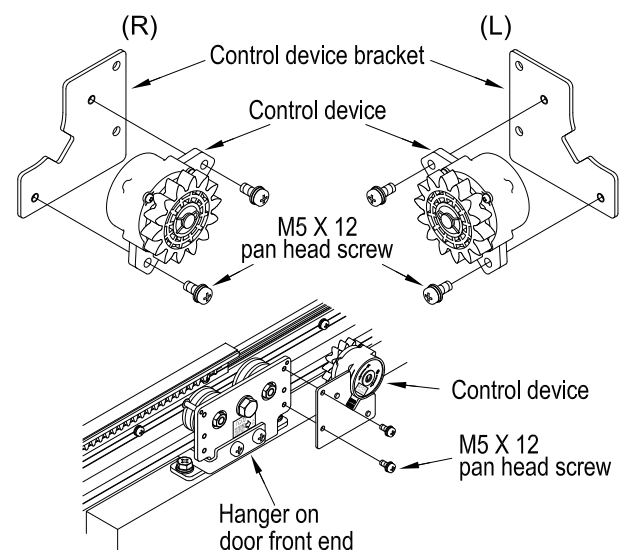

⚠ Caution

- Check the orientation of the control device (right- or left-handed). Be sure to orient it correctly, or the control will not work.
- Be sure to install the control device after mounting the door. When suspending and mounting it, the door may strike and damage the rail or other component.

7 Installing a pull spring

1) Installing a pull spring

- Temporarily tighten the screws (M4 X 5 pan head screws) furnished with the product, on the fittings for installing the pull spring. Then insert them into the T groove in the bottom of the rail.
- Tighten the screws to fix the fittings. Install the pull spring on the fittings for installing the pull spring, with screws (M3 X 8 pan head screws) furnished with the product.

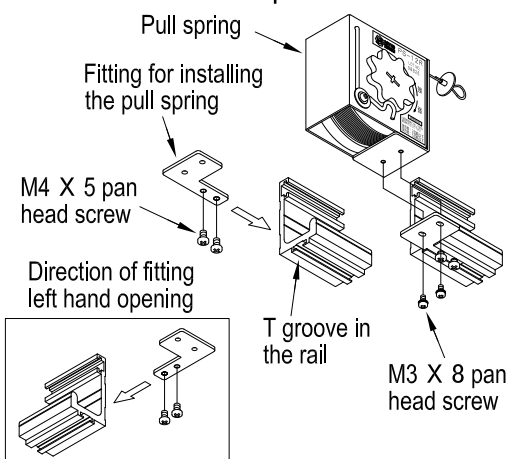

⚠ Caution

- Do not draw the wire with the pull spring alone (before the installation). Any such practice might scratch the wire.

2) Setting the wire

- Draw the wire of the pull spring, then hook it on the hanger on the door front end.

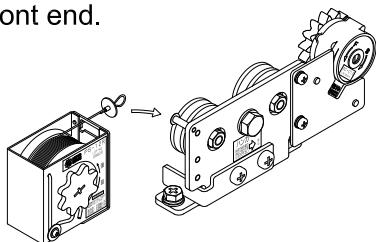

8 Installing the stop device

1) Installing the stop roller and plate spring

- Install the stop roller on the hanger on the door front end with screws (M5 X 8 pan head screws) furnished with the product.
- Insert the plate nuts in the T groove in the rail, then install the plate spring with screws (M4 X 8 truss screws) furnished with the product.

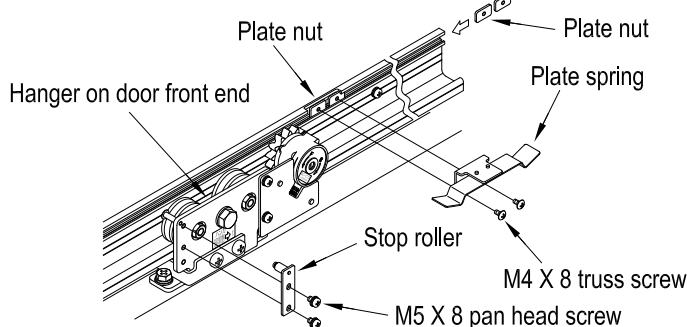

⚠ Caution

- Be sure to use the specified screws furnished with the product. Using any unspecified screw may cause it to interfere with another component.
- Securely tighten the screws furnished with the product, to keep the stop roller and plate spring in place at all times.

2) Adjusting the stopping position and force

- Adjust the position of the plate spring to stop it at the position where the door is fully open.
- Move the stop roller up and down to adjust the stopping force.
 - Increase the stopping force. Raise the stop roller.
 - Reduce the stopping force. Lower the stop roller.

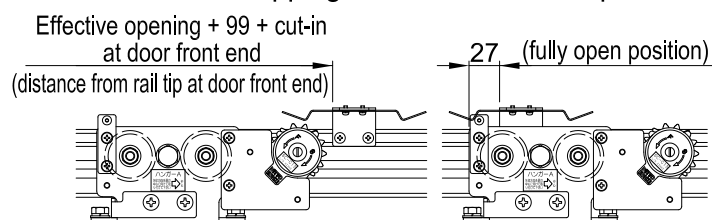

When the clutch gear is inserted or removed, be sure to turn it as following instruction

9 Adjusting the closing force and closing speed

1) Adjusting the closing force

- If the closing force needs to be adjusted, turn the gear shaft with a screwdriver.
- Be aware that direction of rotation is different for left-handed opening or right-handed opening.

Right-handed Left-handed

- Strong "強" Strong "強"
To increase the closing force.
- Weak "弱" Weak "弱"
To decrease the closing force.

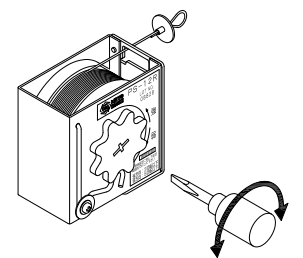

⚠ Caution

- Over winding in the direction of "strong" will cause a breakdown. Be sure to set it to a value not exceeding the number of windings indicated on the sticker on the component.

2) Adjusting the closing speed

- Turn the speed adjusting screw of the control device with a screwdriver to adjust the closing speed.

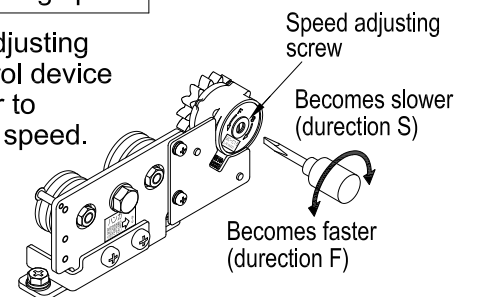

- Slide the control rack set to adjust the controlling interval, thus adjusting the closing speed.
 - Shorten the controlling interval → to increase the closing speed.
 - Elongate the controlling interval → to decrease the closing speed.

⚠ Caution

- Turn the speed adjusting screw lightly. Otherwise an imperfect control may result. After turning it all the way home, do not turn it with overstrain.
- Change of the ambient temperature varies the closing speed somewhat. As the temperature rises, the speed increases. As the temperature declines, the speed decreases.

Procedure for assembling and reengaging the clutch gear

The control device used for this product is for both orientations (right- and left-handed). The orientation of the clutch gear determines whether it is right- or left-handed. When assembling and reengaging the clutch gear, follow the procedure described below.

1. Procedure for assembling the clutch gear

- Insert the washer into the shaft of the control device.
- Insert the clutch gear into the shaft.
 - If right-handed**
Make the white surface (the R-stamped surface) at the center of the clutch gear face upwards, then insert it while turning it in the direction of the arrow for the right-handed opening type illustrated in the right-hand diagram.
 - If left-handed**
Make the blue surface (the L-stamped surface) at the center of the clutch gear face upwards, then insert it while turning it in the direction of the arrow for the left-handed opening type illustrated in the right-hand diagram.
- Install the snap retainer in the groove at the tip of the shaft.

2. Procedure for reengaging the clutch gear

- Remove the clutch gear in reverse order of assembly. (Remove the clutch gear while turning it in the same direction as in assembly.)
- Assemble the clutch gear according to the assembly procedure.
- The product comes with one spare snap retainer.

