

SIDE-LOAD BOTTOM PIVOT ASSEMBLY, 70mm PIVOT POINT

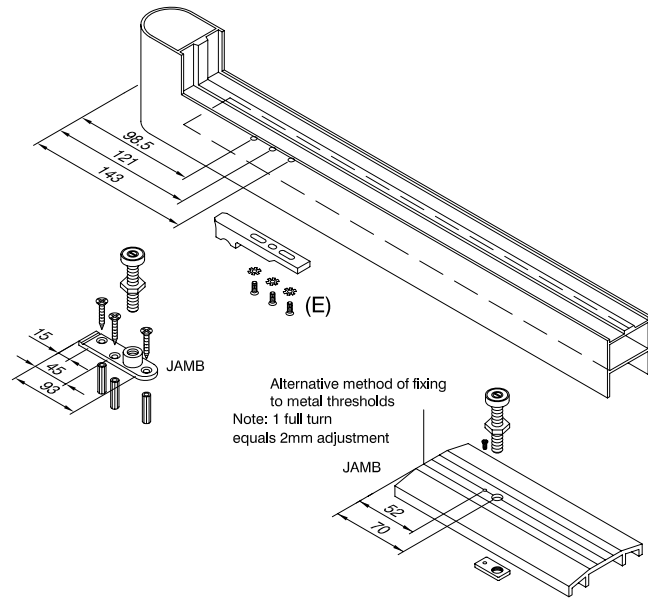

Prepare the bottom rail of the door to accommodate the pivot shoe with 2No. drilled and tapped M6 holes at 98.5mm and 143mm centres.
Fit pivot shoe to underside of door, through the slotted holes with 2No. M6 x 10mm round head screws and lock-washers.
The centre hole should be drilled and tapped on site when correct alignment of the door has been achieved. **THIS FINAL FIXING MUST BE USED.**

If an aluminium threshold is being used prepare as shown below.

The 5mm thick plate is held in position by the M5 countersunk screw and the pivot bolt can be installed. Determine the correct height of the pivot and tighten the locknut.
If the bolt protrudes below the base of the threshold excess must be removed or the floor level drilled accordingly.

TO ERECT THE DOOR

Holding door at approximately 15 degrees, lower onto the pivot bolt and swing the door into the vertical position locating the closer spindle into the arm recess.

Note: To ease the hanging of single action doors it may be necessary to temporarily remove the door stop if already fitted.

Wedge the door in position and fit the arm clamp block with the 3No. socket head screws and conical lock washers. Use allen key provided to tighten block down securely.
Fit tag plate to top rail cut-out. Align door to jamb and meeting stile by adjusting screw (C) and bolts (D). Fit final fixing screw in bottom pivot shoe and tighten all fixings securely.

22

CONCEALED OVERHEAD DOOR CLOSER CENTRE PIVOTED - DOUBLE OR SINGLE ACTING

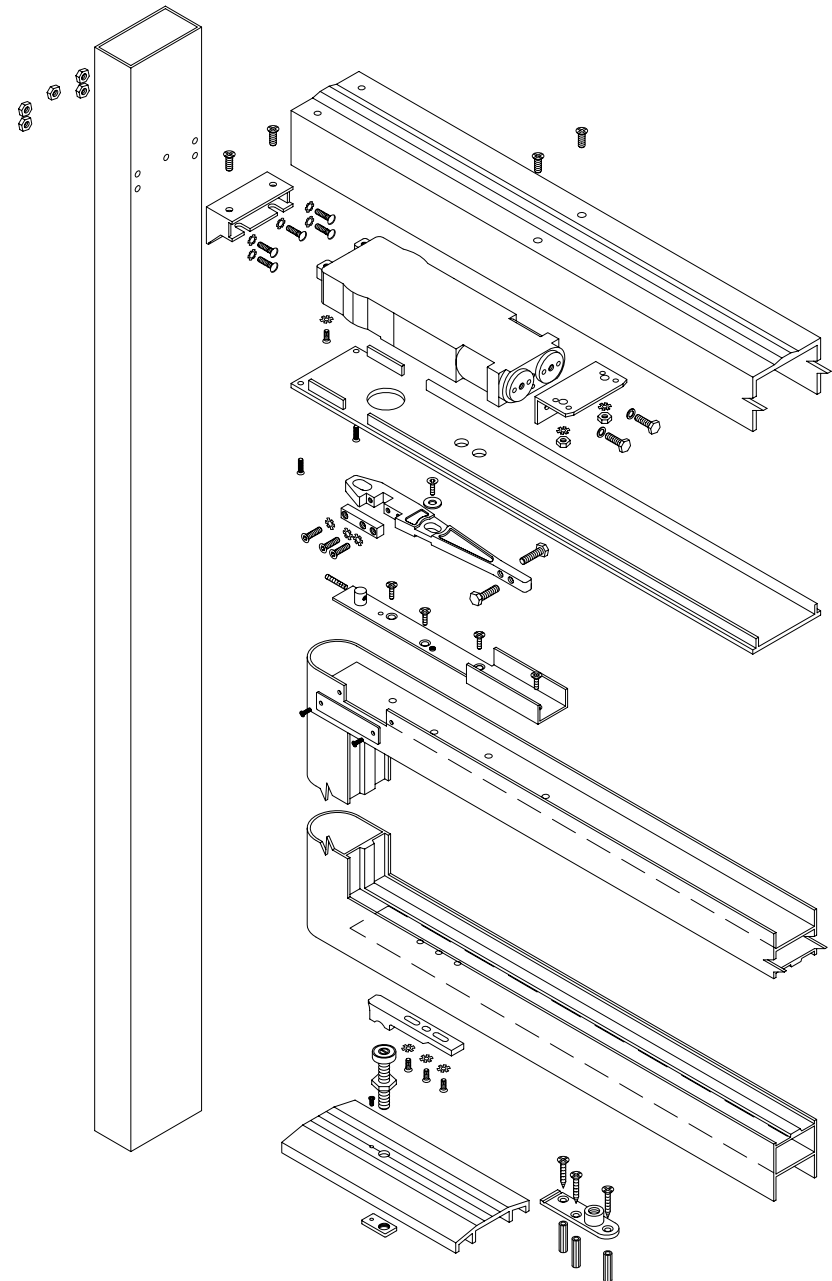

TRANSOM/HEADER BAR, 70mm PIVOT POINT

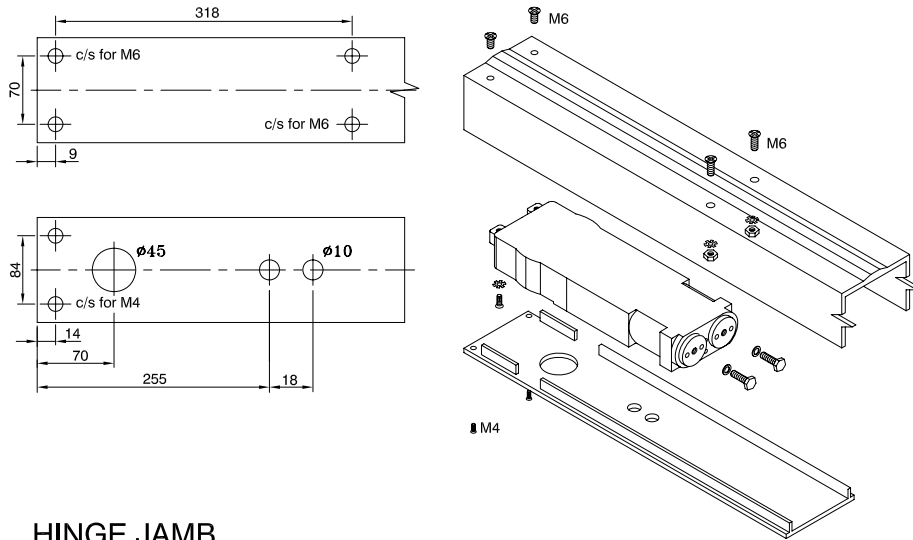

HINGE JAMB

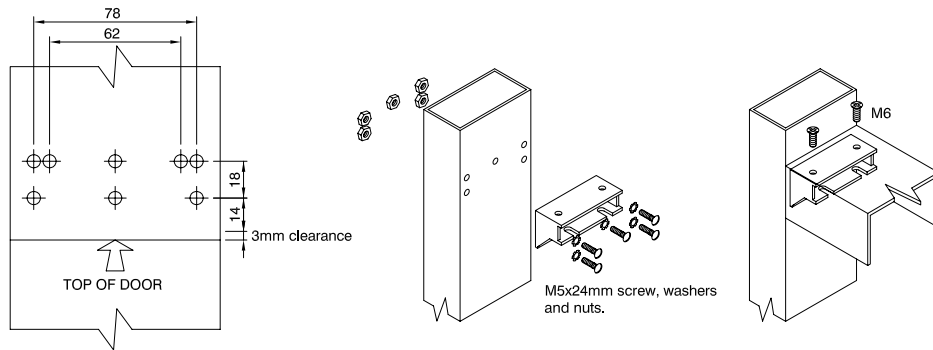

Select fixing holes most suitable for section and drill clearance size for M5 screws.

Prepare transom/header bar and cover plate to accept closer as detailed below.
 Fit jamb bracket to jamb with the 5No. M5x24mm screws, washers and nuts.
 Drill clearance holes and countersink header bar for 2No. M6x10mm screws and 2No. M6x15mm CSK bolts.
 Fit steel angle bracket to header bar using the 2No. M6x15mm bolts, locking washers and nuts.

Locate the 2 fixing lugs into jamb bracket and raise the rear end of the closer into position.
 Fit the 2No. 1/4"x1/2"L Hexagon head bolts and flat washers through the angle bracket and the 2No. 1/4"x5/8"L Round head screws and lock washers into the closer lugs.
 Check the 70mm pivot position, centralise the closer and secure all fixings.

SIDE-LOAD TOP ARM AND CHANNEL, 70mm PIVOT POINT

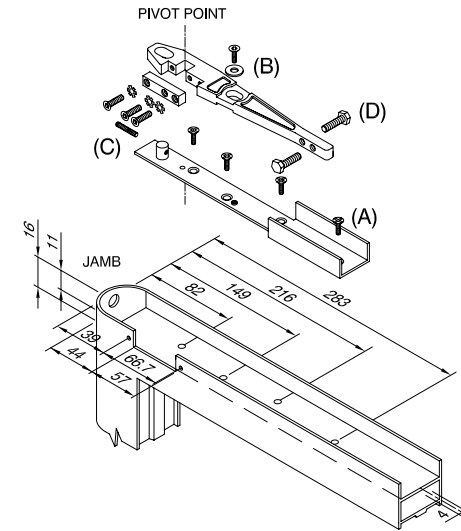

Prepare the top rail of the door as detailed, ensuring that the internal faces of the stile and top rail have been cut away to enable the closer spindle to be engaged during door hanging.
 Drill 7mm hole in the heel of the door giving access to the adjustment screw (C).
 Fit steel arm channel to the door top rail using the 4No. M6 csk screws (A).
 Fit the adjustment screw (C) into the channel post and the 2No. alignment bolts into the arm.
 Place the arm into the channel and fit the large countersunk washer and socket head screw (B).
 Slide the arm centrally over the pre-punched pivot point mark in the channel and adjust position with screw (C).
 Unwind alignment bolts (D) equally on to the steel channel upstands. Tighten all fixings.

TO ADJUST THE DOOR CLOSING SPEED

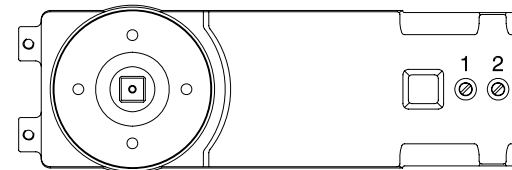

CLOSING SPEED ADJUSTMENT



TURN CLOCKWISE FOR SLOWER SPEED
 ANTI-CLOCKWISE FOR FASTER SPEED

DOOR SWING

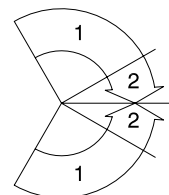

1. CLOSING RANGE
 2. LATCHING RANGE