



Excellence in door opening + closing solutions



Sliding Door Closer

Self Closing Technology

Product Catalog



<http://kenwa-america.com/>

SLIDING DOOR CLOSER

New-generation sliding door closers developed with user-friendly technologies.

Horizontal for Bathroom
NSC-CB

Horizontal
NSC

Incline
DSC-C

We propose a whole new style of door opening/closing solution.

New sliding door closer DSC-C (incline) and NSC-C (horizontal) series

"Innovation and Simplicity"



Long service life:

A long lasting product life time is achieved by our cutting-edge technologies, employed in the compact control device, fluid friction resistance and one-way clutch brake mechanism.

Easy and quick installation:

The only preparation needed before installation is to drill screw holes into the door frame for mounting rail. After that, all parts/devices can be installed by a screwdriver from the front, easily and efficiently.

Light and smooth opening:

The system is designed to assist in reducing the door opening resistance to achieve an easy and safe opening operation for all, including the elderly, small children, people of limited mobility and people who are otherwise carrying large packages or groceries. (Ref: Initial door-opening force is 6.7N with DSC-C08 model and 5.7N with NSC-C48 model when used on 40kg door.)

Wide variety of models:

A wide variety of models are available for different door types (wooden/steel/aluminum) and sizes (width/weight). Options for Interlocking sliding door and bi-parting configurations are also available.

Non-handed design, right/left convertible:

The system can be used for both left and right hand sliding doors. It can be easily converted between left and right handing by a simple adjustment procedure.



Fire door type

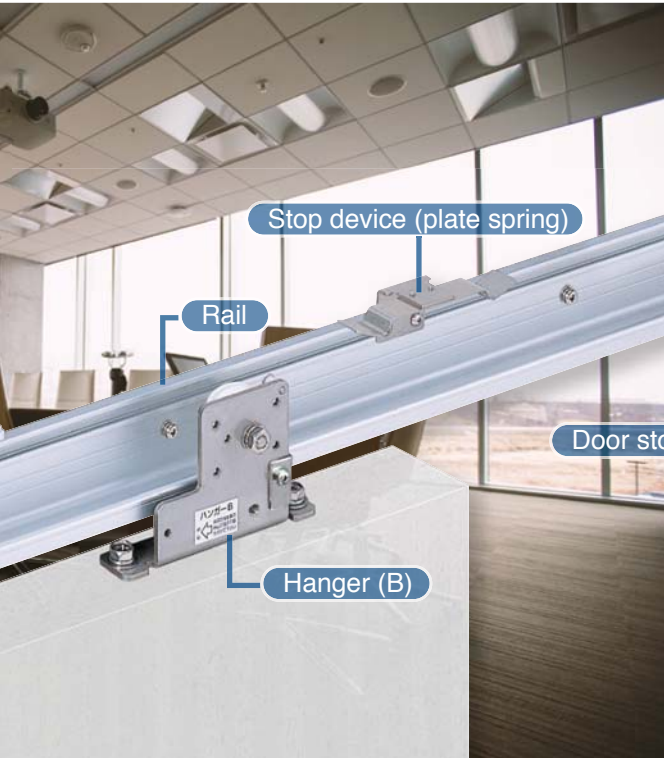
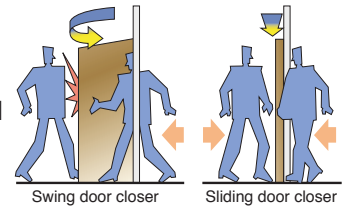


In-wall mount type



Special Order

NITTO KOHKI Sliding Door Closer is an ideal solution eliminating dead space and ensuring safety.



INDEX

Application

Applicable door	Model	Door weight (kg)	Applicable door width (mm)	Page
-----------------	-------	------------------	----------------------------	------

For wooden doors, incline type DSC-CW series

Wooden doors	DSC-CW30V	10-30	600-1600	5
	DSC-CW60V	30-60		
	DSC-CW03	10-30	700-1600	7
	DSC-CW08	30-80		

For light steel doors, incline type DSC-C series

Steel doors	DSC-C30V	10-30	600-1600	6
	DSC-C60V	30-60		
	DSC-C03	10-30	700-1600	9
	DSC-C08	30-80		
	DSC-C015	80-150		

For wooden doors, horizontal type NSC-CW series

Wooden doors	NSC-CW60V	10-60	600-1600	17
	NSC-CW23	10-30	700-1600	19
	NSC-CW48	30-80		20

For light steel doors, horizontal type NSC-C series

Steel doors	NSC-C60V	10-60	600-1600	18
	NSC-C48	10-80		21
	NSC-CB48 (for bathrooms)	10-80	700-1600	22
	NSC-C1215	80-150		23
	NSC-C2525	150-250	900-2500	24

Option

Model	Page
Interlocking sliding door	32
Bi-Parting, SC-W	35
Free stop device	36
Delayed device	38
Back check device	41
Air damper	42
Close assist device	43

Application

For fire doors made of light steel
DSC-CF/NSC-CF series

Applicable door	Model	Door weight (kg)	
Fire doors	DSC-C08F	30-80	Contact us for further information
	DSC-C015F	80-150	
	NSC-C48F	30-80	
	NSC-C1215F	80-150	
	NSC-C2525F	150-250	

Application

For pocket doors made of wood/light steel
DSC-CKS/NSC-CKS series

Applicable door	Model	Door weight (kg)	
Pocket doors	incline	10-80	Contact us for further information
	DSC-CKS serie		
	horizontal		
	NSC-CKS series		

Email to kentokyo@nitto-kohki.co.jp

Option

DSC-C (incline) series

Applicable door	Model	Option						
	incline DSC-C	Free stop device	Delayed device	Back check device	Bi-Parting, SC-W	Interlocking sliding door, SC-2S	Close assist	Air Damper
Wooden doors	DSC-CW30V	●	●	●	●	●	●	●
	DSC-CW60V	●	●	●	●	●	●	●
	DSC-CW03	●	●	●	●	●	●	●
	DSC-CW08	●	●	●	●	●	●	●
Steel doors	DSC-C30V	●	●	●	●	●	●	●
	DSC-C60V	●	●	●	●	●	●	●
	DSC-C03	●	●	●	●	●	●	●
	DSC-C08	●	●	●	●	●	●	●
	DSC-C015	●		●	●			●

NSC-C (horizontal) series

Applicable door	Model	Option						
	horizontal NSC-C	Free stop device	Delayed device	Back checker device	Bi-Parting, SC-W	Interlocking sliding door, SC-2S	Close assist	Air Damper
Wooden doors	NSC-CW60V	●	●	●	●	●	●	●
	NSC-CW23	●	●	●	●	●	●	●
	NSC-CW48	●	●	●	●	●	●	●
Steel doors	NSC-C60V	●	●	●	●	●	●	●
	NSC-C48	●	●	●	●	●	●	●
	NSC-C1215	●		●	●			
	NSC-C2525							

Remark

1. Only one of the following options can be used on one system. (Multiple options cannot be used together.)
Free stop device / delayed device / back check device
2. The option device(s) may not be able to use depending on the shape of door frame.

DELAYED DEVICE

Function

- Delayed device can control closing time at door full open. Therefore, it helps aged person, handicapped and also when carrying goods.
- Closing time can be adjusted from 0-15 sec.



FREE STOP DEVICE

Function

- The door can be stopped at any desired position. To release, lightly pull the door to closing direction so the door will automatically close.
- This device is an option.
- Non handed, suitable for left or right hand opening.



CLOSE ASSIST DEVICE

Function

- Close assist device helps door closed at 25mm when door can not be closed perfectly because of latching resistance, by electronic lock or airtight material (Mohair, Seal) And also this device is prevented from door jumped when door is closed strongly. Pulling force can adjustmentable from 5N-10N



AIR DAMPER UNIT

- Air damper can be installed sliding door closer C and CV series under 80kg door.

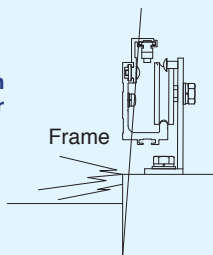


Sliding Door Closer Troubleshooting Q&A

Q: The door does not fully close.

A: Some part of door, hanger or other components may be in contact with the top cover or door pocket.

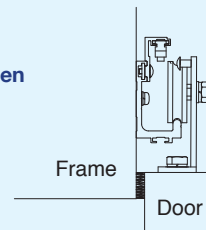
Action: Check the point of contact and then adjust or reinstall the hanger(s)/ guide roller for correcting the position and make sure there is no contact against the top cover or door pocket.



Q: The door does not fully close or closing motion is not smooth/steady.

A: There may be friction/resistance against door from some object between the door and the frame (such as an airtight rubber, mohair etc.)

Action: Reduce the friction by modifying the object (changing material, shape, size etc.)



A: The guide roller may be in contact with the top surface of the guide rail (bottom of the door) so that the door does not move smoothly.

Action: Raise the door by adjusting the hanger bracket or even move the rail location up if more clearance is needed.



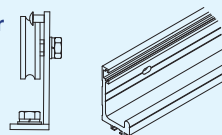
A: The door may be not perpendicular (vertical) to the floor and therefore the door may be tilting/leaning away from the wall.

Action: Reinstall the hanger(s) and/or guide roller to make sure that the door becomes perpendicular to the floor.



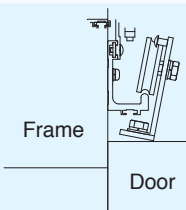
A: There may be dusts, obstacles or damage on the hanger roller or the surface of rail.

Action: Clean hanger roller/rail or replace them if necessary.



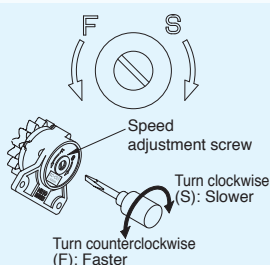
A: The hanger(s) may not be installed parallel to the rail and the hanger roller is not rolling in-line on the rail correctly.

Action: Adjust or reinstall the hanger(s) and make sure that the roller becomes in-line to the rail.

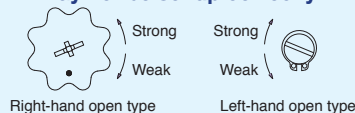


A: The control device may not be set up correctly (weak spring strength) and the system may be braking too strongly.

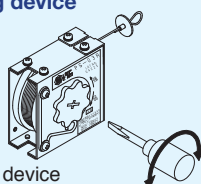
Action: Turn the speed adjustment dial on the control device counterclockwise and adjust the braking speed correctly.



A: (For Horizontal Type) The pull spring device may not be set up correctly.

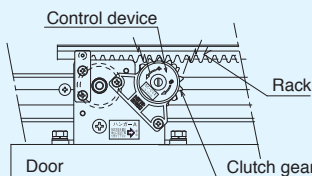


Action: Adjust the spring force of pull spring device and set it to suitable tension.



A: The clutch gear of the control device may be engaged too strongly to the rack.

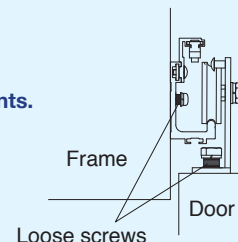
Action: Adjust the height of rack within allowance of screw hole.



Q: The door makes rattling noise.

A: Check the conditions of mounting screws for all components.

Action: Tighten any loose screws.



Precautions for preventing accidents

1. Use the product only with suitable door size, weight, material and location as specified in this catalog.
2. In case the control device fails, the door may close fast increasing risk of accident, such as finger pinch, collision, tripping etc... If you observe a malfunction of braking performance due to an oil leak or parts breakage, please replace the product/part immediately.
3. Do not disassemble or modify the product. Any product dismantled/modified shall not be subject to manufacturer's warranty.
4. Make sure that all of the mounting screws are securely fastened. Loose or damaged screws may cause product failure or accident.
5. Be sure to install the anti-bounce brackets. Failure to observe this instruction may result in derailing of hangers or tripping of door.
6. Be sure to install the door stopper at the door back end.
7. Do not drop or strike any of the components. Failure to follow this precaution may cause a fault in operation.
8. While the door is being closed automatically by this product, do not close the door by hand too strongly. Excessive closing force may cause door to close too rapidly and result in accident.
9. Do not hang on to the door or rail.
10. In case the door hits the standard door stopper too strongly, install additional door stopper at the door back end or on the floor.
11. Do not pull out the wire and abruptly release your hand, otherwise the wire would be too strongly rolled back and get jammed/bent inside. (If the wire gets damaged, it would no longer be properly pulled or retracted. Once this happens, please replace the pull spring device.)

Precautions to be taken to ensure a long service life

1. Wipe off dust from the rail and rollers periodically.
2. Check the condition of product periodically and make sure all components are securely installed and properly working.

Highly reliable and cost effective self-closing solution for wooden sliding doors.
Safe & long term operation guaranteed.
Simple to install, set up and use.



Features

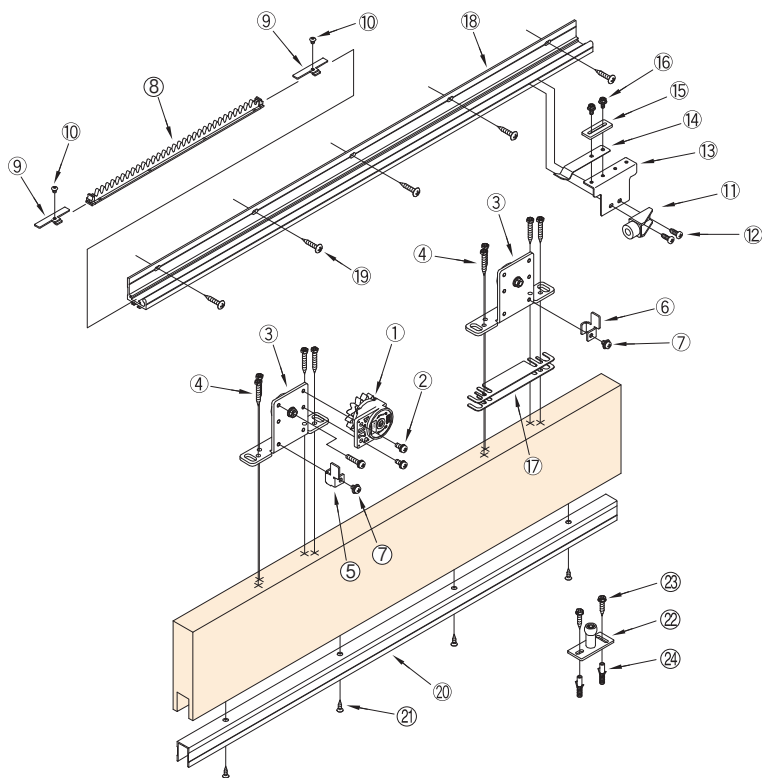
- All parts required for inclining installation on wooden door (e.g. guide rail, guide roller, stop device, etc.) are included in standard component.
- The product can be used for both left and right hand sliding doors and can be easily converted between left and right by simple adjustment.

Specifications

right and left handed opening

Model		DSC-CW30V-22	DSC-CW30V-31	DSC-CW60V-22	DSC-CW60V-31
Applicable doors	Weight [kg]	10-30		30-60	
	Width [mm]	600-1,200	1,200-1,600	600-1,200	1,200-1,600
Max. stroke [mm]		1,500			
Closing drive system		Rail inclination (3.5/300)			
Controlling system		Fluid friction resistance type			
Working Pressure Range		7-11 seconds (with a door-opening distance of 900mm)			
Initial opening force [N]		2.3 (Door weight 10kg), 6.1 (Door weight 30kg)		6.1 (Door weight 30kg), 11.6 (Door weight 60kg)	
Durability		More than half million open/close operations			
Control device		SC-C03V		SC-C06V	
Rail length [m]		2.2	3.1	2.2	3.1
Guide rail length [m]		1.3	1.6	1.3	1.6

Part details

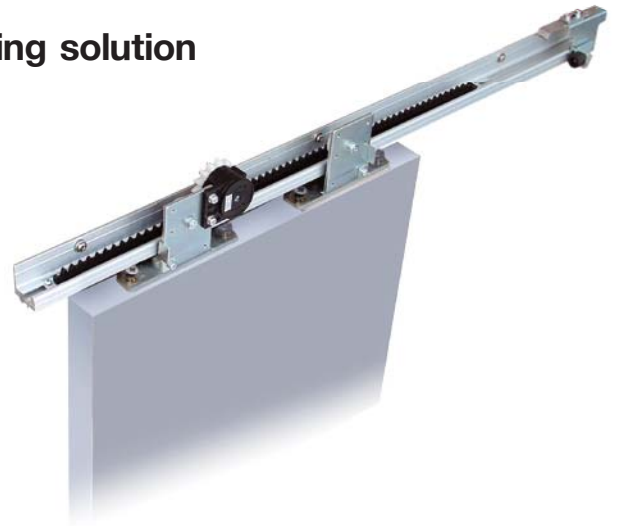


No.	Part	Q'ty	Remark
①	Control device	1	For control device
②	M5×12 pan head screw	2	
③	Hanger	2	For hanger
④	M5×35 Cross recessed hexagon head tapping screw	8	
⑤	Door retaining fitting L	1	Door retention
⑥	Door retaining fitting R	1	
⑦	M5×8 pan head screw	2	For control rack set
⑧	Control rack	1	
⑨	Control rack fitting	2	For control rack set
⑩	M4×5 hexagon socket button head screw	2	
⑪	Door stopper	1	For door stopper
⑫	Φ5×16 pan head drill screw	2	
⑬	Plate spring bracket	1	For stop device
⑭	Plate spring	1	
⑮	Stop force adjusting plate	1	
⑯	M4×10 Cross recessed hexagon screw	2	
⑰	Height adjusting plate (t=1.0)	16	For rail
⑱	Rail L=2200[L=3100]	1	
⑲	Φ5×30 truss head tapping screw	8[11]	For guide rail
⑳	Guide rail L=1300[L=1600]	1	
㉑	Φ4×16 countersunk head tapping screw	4[5]	For guide roller
㉒	Guide roller Φ16	1	
㉓	Φ5×25 Hexagon head tapping screw	2	For guide roller
㉔	M5×12 Hexagon head screw	2	
㉔	Fischer plug 6×30	2	

Highly reliable and cost effective self-closing solution for steel sliding doors.
Safe & long term operation guaranteed.
Simple to install, set up and use.

Features

- All parts required for inclining installation on steel door (e.g. guide rail, guide roller, stop device, etc.) are included in standard component.
- The product can be used for both left and right hand sliding doors and can be easily converted between left and right by simple adjustment.

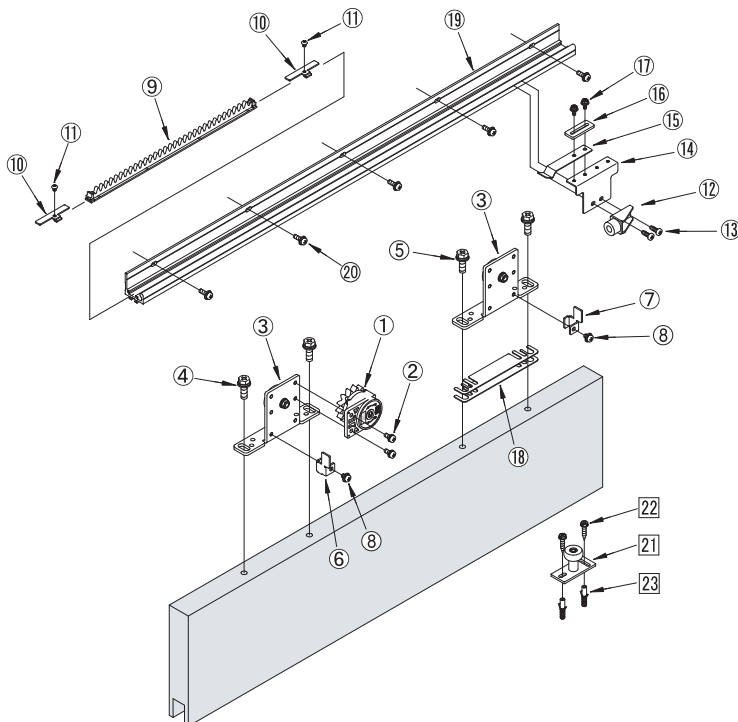


Specifications

right and left handed opening

Model		DSC-C30V-22	DSC-C30V-31	DSC-C60V-22	DSC-C60V-31
Applicable doors	Weight [kg]	10-30		30-60	
	Width [mm]	600-1,200	1,200-1,600	600-1,200	1,200-1,600
Max. stroke [mm]		1,500			
Closing drive system		Rail inclination (3.5/300)			
Controlling system		Fluid friction resistance type			
Working Pressure Range		7-11 seconds (with a door-opening distance of 900mm)			
Initial opening force [N]		2.3 (Door weight 10kg), 6.1 (Door weight 30kg)		6.1 (Door weight 30kg), 11.6 (Door weight 60kg)	
Durability		More than half million open/close operations			
Control device		SC-C03V		SC-C06V	
Rail length [m]		2.2	3.1	2.2	3.1

Part details



No.	Part	Q'ty	Remark
①	Control device	1	For control device
②	M5×12 pan head screw	2	
③	Hanger	2	For hanger
④	M8×25 cross recessed hexagon head screw	2	
⑤	M8×30 cross recessed hexagon head screw	2	
⑥	Door retaining fitting L	1	Door retention
⑦	Door retaining fitting R	1	
⑧	M5×8 pan head screw	2	For control rack set
⑨	Control rack	1	
⑩	Control rack fitting	2	
⑪	M4×5 hexagon socket button head screw	2	For stop device
⑫	Door stopper	1	
⑬	Φ5×16 pan head drill screw	2	
⑭	Plate spring bracket	1	For door stopper
⑮	Plate spring	1	
⑯	Stop force adjusting plate	1	
⑰	M4×10 Cross recessed hexagon screw	2	For rail
⑱	Height adjusting plate (t=1.0)	16	
⑲	Rail L=2200[L=3100]	1	
⑳	M5×16 pan head screw	8[11]	For guide roller
㉑	Guide roller *	1	
㉒	Φ5×25 Hexagon head tapping screw	2	
㉓	M5×12 Hexagon head screw	2	Fischer plug 6×30
㉔	Fischer plug 6×30	2	

*4 types, φ16,25,30,35

Features

- All parts required for inclining installation on wooden door (e.g. guide rail, guide roller, stop device, etc.) are included in standard component.
- Lug screws are included to attach the hangers to the door directly and securely.
- Long life time achieved by endless fluid frictional resistance type braking mechanism.
- The product can be used for both left and right hand sliding doors and can be easily converted between left and right by simple adjustment.
- Quick and easy installation without any special tool.



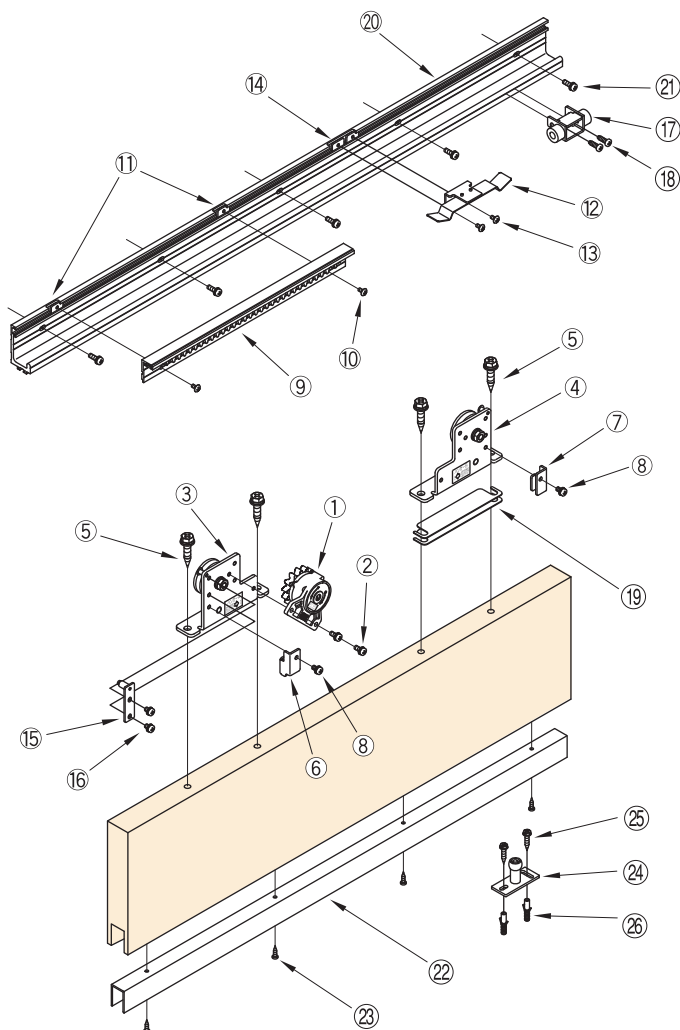
Specifications

right and left handed opening

Model		DSC-CW03-22	DSC-CW03-31
Applicable doors	Weight [kg]	10-30	
	Width [mm]	700-1,200	1,200-1,600
Max. stroke [mm]		1,500	
Closing drive system		Rail inclination (3.5/300)	
Controlling system		Fluid friction resistance type	
Working Pressure Range		7-11 seconds (with a door-opening distance of 900mm)	
Initial opening force [N]		2.5 (Door weight 10kg), 5.4 (Door weight 30kg)	
Durability		More than 1 million open/close operations	
Control device		SC-C03	
Rail length [m]		2.2	3.1
Guide rail [m]		1.3	1.6



Part details



No.	Part	Q'ty	Remark
①	Control device	1	
②	M5×12 pan head screw	2	For control device
③	Hanger A	1	
④	Hanger B	1	For hanger
⑤	φ8×50 coach screw	4	
⑥	Door retaining fitting Hanger A	1	
⑦	Door retaining fitting Hanger B	1	Door retention
⑧	M5X8 pan head screw	2	
⑨	Control rack set	1	
⑩	M4×8 truss head screw	2	For control rack set
⑪	Plate nut	2	
⑫	Plate spring	1	
⑬	M4×8 truss head screw	2	
⑭	Plate nut	2	For stop device
⑮	Stop roller	1	
⑯	M5×8 pan head screw	2	
⑰	Door stopper	1	
⑱	φ5×16 pan head tapping screw	2	For door stopper
⑲	Height adjusting plate (t=1.0, 0.5)	15+1	
⑳	Rail L=2200[L=3100]	1	
㉑	M5×16 pan head screw	8[11]	For rail
㉒	φ5×30 truss head tapping screw	8[11]	
㉓	Guide rail L=1300[L=1600]	1	For guide rail
㉔	φ4×16 pan head tapping screw	5[6]	
㉕	Guide roller φ16	1	
㉖	φ5×25 Hexagon head tapping screw	2	For guide roller
㉗	M5×12 Hexagon head bolt	2	
㉘	Fischer plug 6X30	2	

Features

- All parts required for inclining installation on wooden door (e.g. guide rail, guide roller, stop device, etc.) are included in standard component.
- Long life time achieved by endless fluid frictional resistance type braking mechanism.
- The product can be used for both left and right hand sliding doors and can be easily converted between left and right by simple adjustment.
- Quick and easy installation without any special tool.



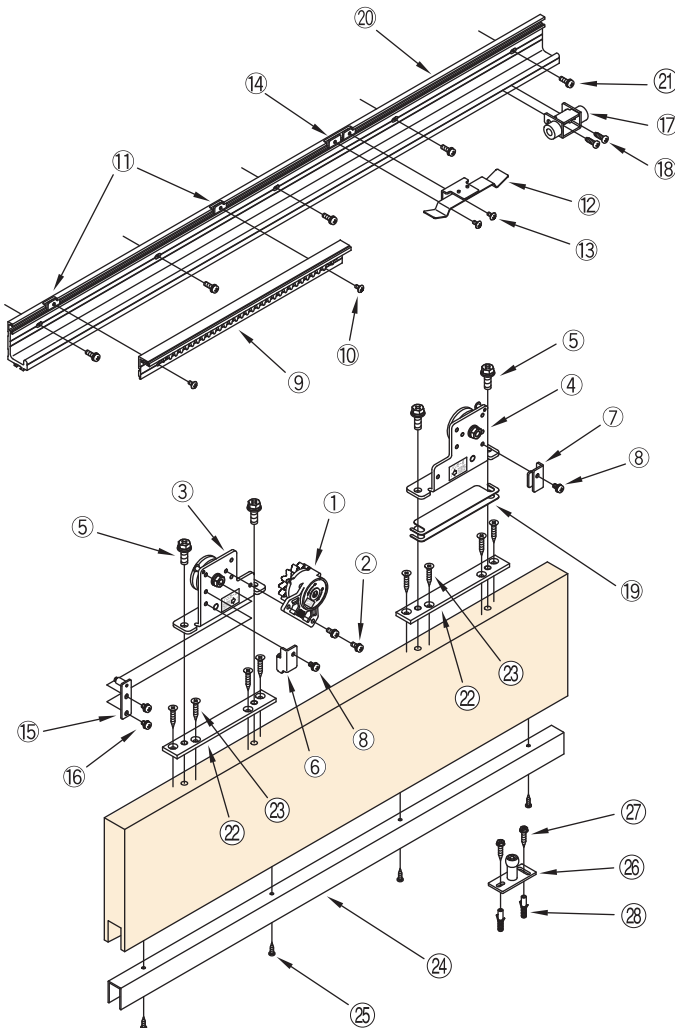
Specifications

right and left handed opening

Model		DSC-CW08-22	DSC-CW08-31
Applicable doors	Weight [kg]	30-80	
	Width [mm]	700-1,200	1,200-1,600
Max. stroke [mm]		1,500	
Closing drive system		Rail inclination (3.5/300)	
Controlling system		Fluid friction resistance type	
Working Pressure Range		7-11 seconds (with a door-opening distance of 900mm)	
Initial opening force [N]		5.4 (Door weight 30kg), 12.5 (Door weight 80kg)	
Durability		More than 1 million open/close operations	
Control device		SC-C08	
Rail length [m]		2.2	3.1
Guide rail [m]		1.3	1.6



Part details



No.	Part	Q'ty	Remark
①	Control device	1	For control device
②	M5×12 pan head screw	2	
③	Hanger A	1	For hanger
④	Hanger B	1	
⑤	φ8×25 cross recessed hexagon head bolt	2	For hanger
⑤	φ8×30 cross recessed hexagon head bolt	2	
⑥	Door retaining fitting Hanger A	1	Door retention
⑦	Door retaining fitting Hanger B	1	
⑧	M5×8 pan head screw	2	For control rack set
⑨	Control rack set	1	
⑩	M4×8 truss head screw	2	For control rack set
⑪	Plate nut	2	
⑫	Plate spring	1	For stop device
⑬	M4×8 truss head screw	2	
⑭	Plate nut	2	For stop device
⑮	Stop roller	1	
⑯	M5×8 pan head screw	2	For door stopper
⑰	Door stopper	1	
⑱	φ5×16 pan head tapping screw	2	For door stopper
⑲	Height adjusting plate (t=1.0,0.5)	15+1	
⑳	Rail L=2200[L=3100]	1	For rail
㉑	M5×16 pan head screw	8[11]	
㉒	φ5×30 truss head tapping screw	8[11]	For wooden door plate
㉓	Wooden door plate	2	
㉔	φ5×30 countersunk head tapping screw	8	For wooden door plate
㉕	Guide rail L=1300[L=1600]	1	
㉖	φ4×16 pan head tapping screw	5[6]	For guide rail
㉗	Guide roller φ16	1	
㉘	φ5×25 Hexagon head tapping screw	2	For guide roller
㉙	M5×12 Hexagon head screw	2	
㉚	Fischer plug 6x30	2	

Features

- All parts required for inclining installation on steel door (e.g. guide rail, guide roller, stop device, etc.) are included in standard component.
- Long life time achieved by endless fluid frictional resistance type braking mechanism.
- The product can be used for both left and right hand sliding doors and can be easily converted between left and right by simple adjustment.
- Quick and easy installation without any special tool.

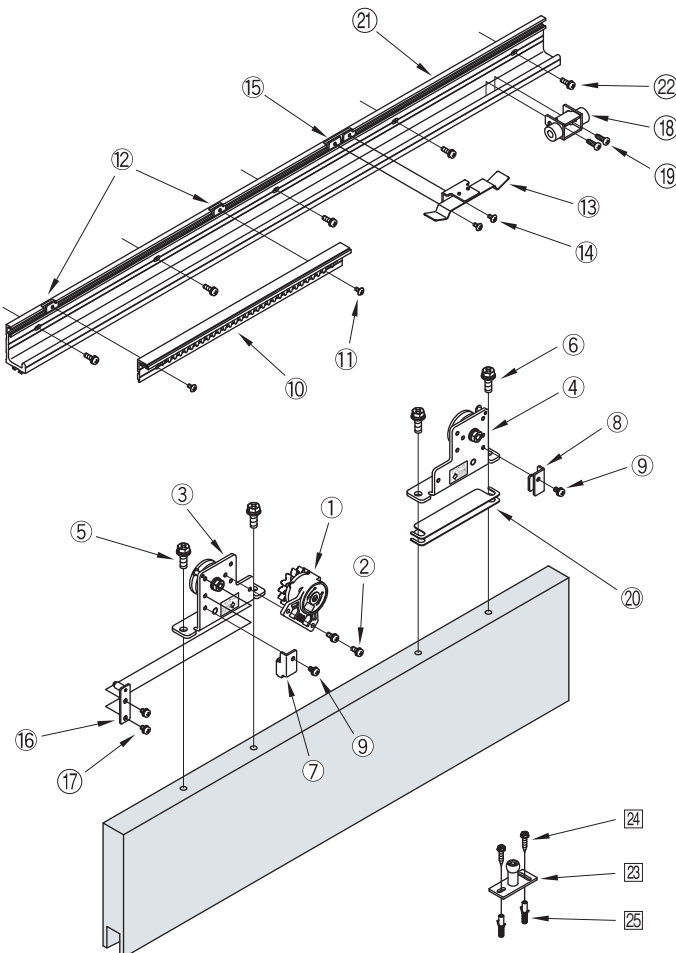


Specifications

right and left handed opening

Model		DSC-C03-22	DSC-C03-31	DSC-C03-22	DSC-C03-31
Applicable doors	Weight [kg]	10-30		30-80	
	Width [mm]	700-1,200	1,200-1,600	700-1,200	1,200-1,600
Max. stroke [mm]		1,500			
Closing drive system		Rail inclination (3.5/300)			
Controlling system		Fluid friction resistance type			
Controlling time		7-11 seconds (with a door-opening distance of 900mm)			
Initial opening force [N]		2.5 (Door weight 10kg), 5.4(Door weight 30kg)		5.4 (Door weight 30kg), 12.5 (Door weight 80kg)	
Durability		More than 1 million open/close operations			
Control device		SC-C03		SC-C08	
Rail length [m]		2.2	3.1	2.2	3.1

Part details

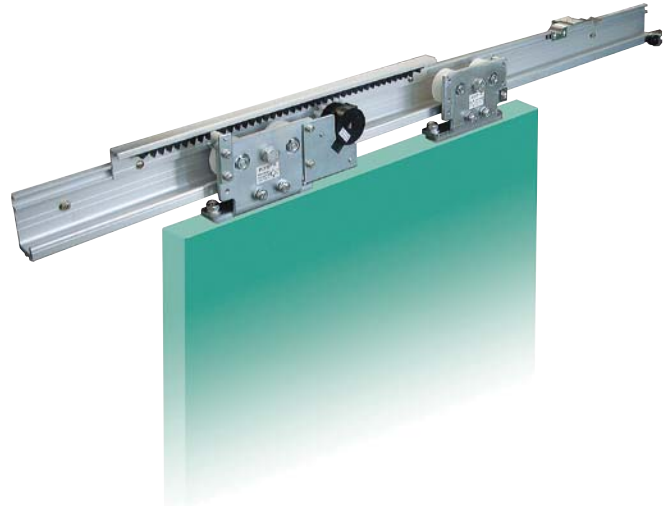


No.	Part	Q'ty	Remark
①	Control device	1	For control device
②	M5×12 pan head screw	2	
③	Hanger A	1	For Hanger
④	Hanger B	1	
⑤	M8×25 cross recessed hexagon head bolt	2	Door retention
⑥	M8×30 cross recessed hexagon head bolt	2	
⑦	Door retaining fitting Hanger A	1	Door retention
⑧	Door retaining fitting Hanger B	1	
⑨	M5×8 pan head screw	2	For stop device
⑩	Control rack set	1	
⑪	M4×8 truss head screw	2	For control rack set
⑫	Plate nut	2	
⑬	Plate spring	1	For stop device
⑭	M4×8 truss head screw	2	
⑮	Plate nut	2	For stop device
⑯	Stop roller	1	
⑰	M5×8 pan head screw	2	For door stopper
⑱	Door stopper	1	
⑲	φ5×16 pan head tapping screw	1	For rail
⑳	Height adjusting plate (t=1.0,0.5)	15+1	
㉑	Rail L=2200[L=3100]	1	For rail
㉒	M5×16 pan head screw	8[11]	
㉓	φ5×30 truss head tapping screw	8[11]	For guide roller
㉔	Guide roller *	1	
㉕	φ5×25 Hexagon head tapping screw	2	For guide roller
㉖	M5×12 Hexagon head screw	2	
㉗	Fischer plug 6×30	2	

*4 types, φ16, 25, 30, 35

Features

- All parts required for inclining installation on heavy steel door (e.g. guide rail, guide roller, stop device, etc.) are included in standard component.
- Long life time achieved by endless fluid frictional resistance type braking mechanism.
- Adopting longer control rack, the damper (braking) range has become 1.5 times wider than conventional model.
- The product can be used for both left and right hand sliding doors and can be easily converted between left and right by simple adjustment.
- Quick and easy installation without any special tool.

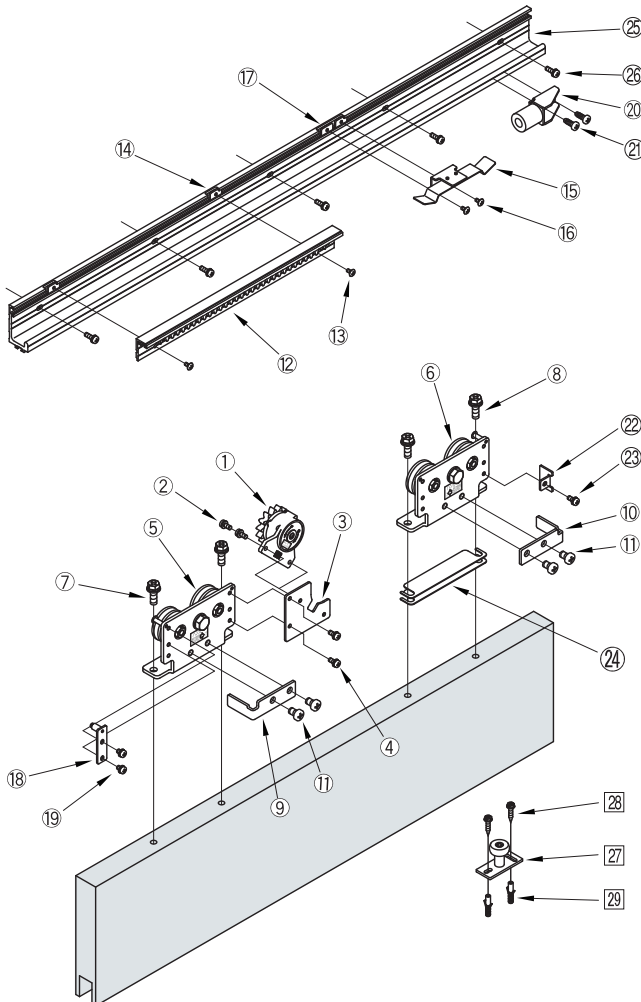


Specifications

right and left handed opening

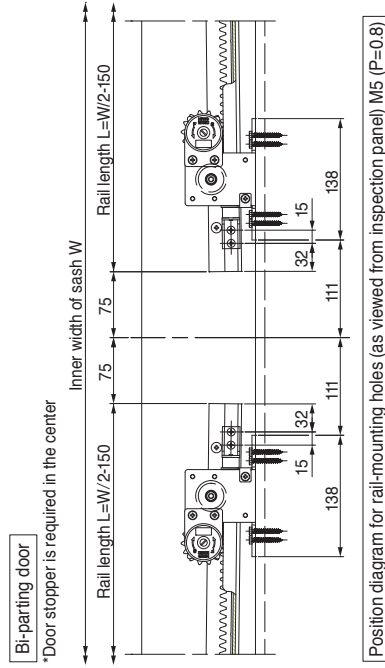
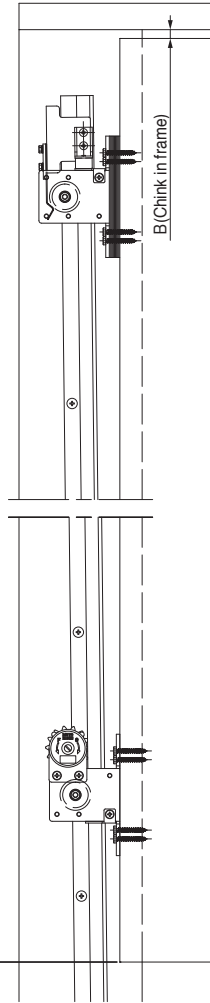
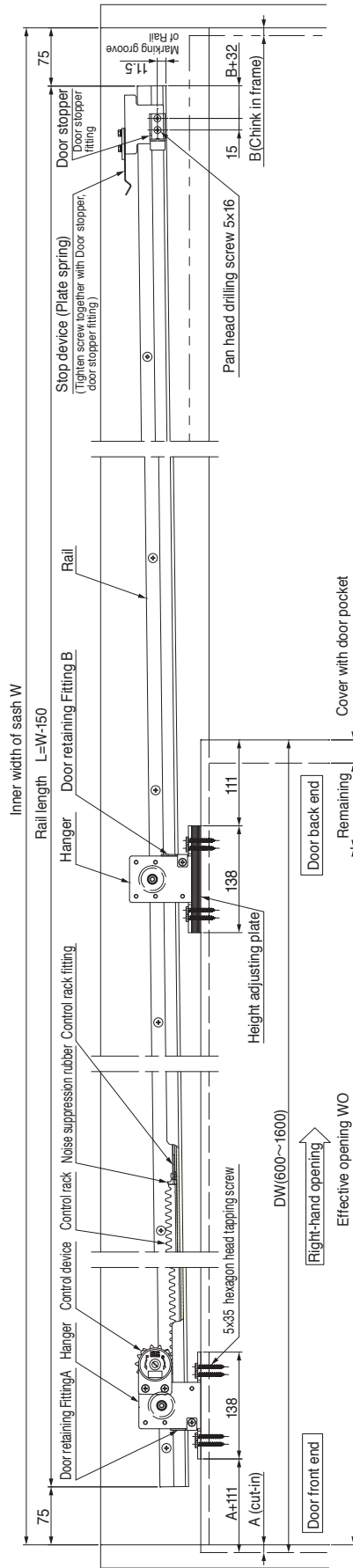
Model		DSC-C015-22	DSC-C015-31
Applicable doors	Weight [kg]	80-150	
	Width [mm]	700-1,200	1,200-1,600
Max. stroke [mm]		1,500	
Closing drive system		Rail inclination (3.5/300)	
Controlling system		Fluid friction resistance type	
Controlling time		7-11 seconds (with a door-opening distance of 900mm)	
Initial opening force [N]		12.5 (Door weight 80kg), 24.0 (Door weight 150kg)	
Durability		More than 1 million open/close operations	
Control device		SC-C15	
Rail length [m]		2.2	3.1

Part details

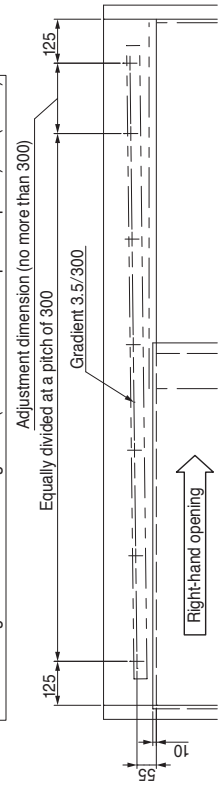


No.	Part	Q'ty	Remark
①	Control device	1	For control device
②	M5×12 pan head screw	2	
③	Control device bracket	1	
④	M5×12 pan head screw	2	For Hanger
⑤	Hanger A	1	
⑥	Hanger B	1	Door retention
⑦	M8×25 cross recessed hexagon head bolt	2	
⑧	M8×30 cross recessed hexagon head bolt	2	For control rack set
⑨	Door retaining fitting Hanger A	1	
⑩	Door retaining fitting Hanger B	1	For stop device
⑪	M8×12 pan head screw	4	
⑫	Control rack set	1	For door stopper
⑬	M4×8 truss head screw	2	
⑭	Plate nut	2	For rail
⑮	Plate spring	1	
⑯	M4×8 truss head screw	2	For guide roller
⑰	Plate nut	2	
⑱	Stop roller	1	For rail
⑲	M5×8 pan head screw	2	
⑳	Door stopper	1	For door stopper
㉑	φ6×19 Pan head drilling screw	2	
㉒	Door stopper bearing plate	1	For rail
㉓	M5×8 pan head screw	1	
㉔	Height adjusting plate (t=1.0, 0.5)	15+1	For guide roller
㉕	Rail L=2200[L=3100]	1	
㉖	M5×16 pan head screw	8[11]	For guide roller
㉗	φ5×30 pan head tapping screw	8[11]	
㉘	Guide roller *	1	For guide roller
㉙	φ5×25 Hexagon head tapping screw	2	
㉚	M5×12 Hexagon head screw	2	
㉛	Fischer plug 6×30	2	

*4 types, φ16, 25, 30, 35



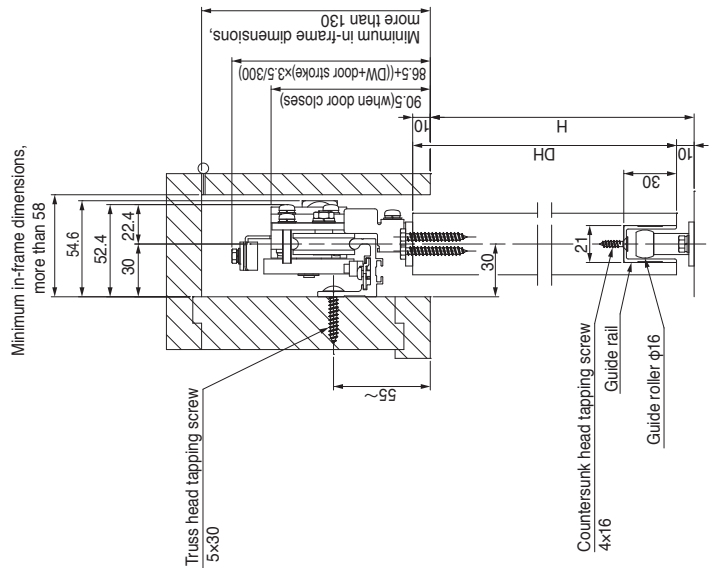
Position diagram for rail-mounting holes (as viewed from inspection panel) M5 (P=0.8)

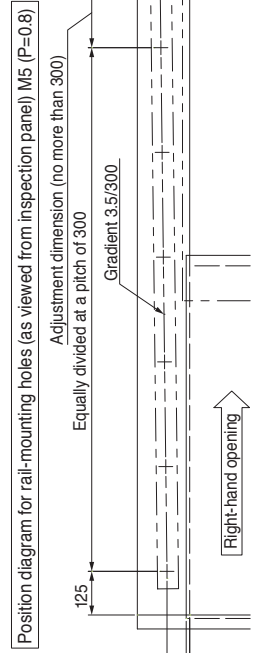
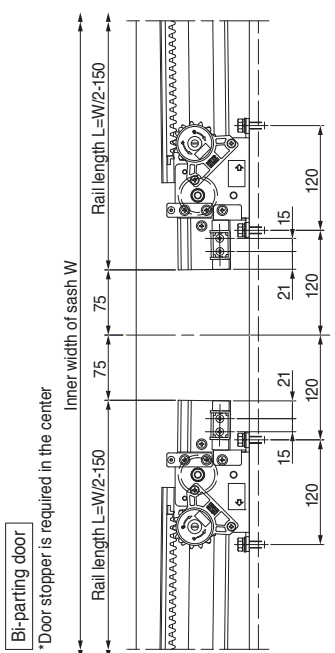
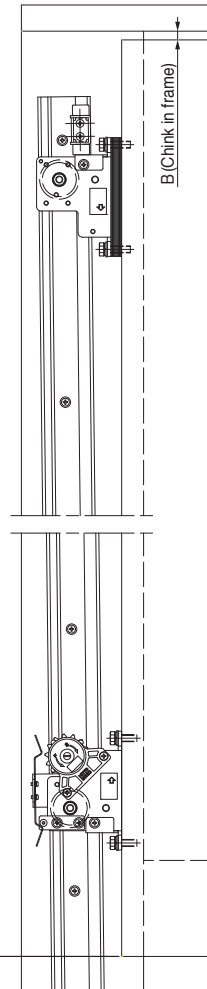
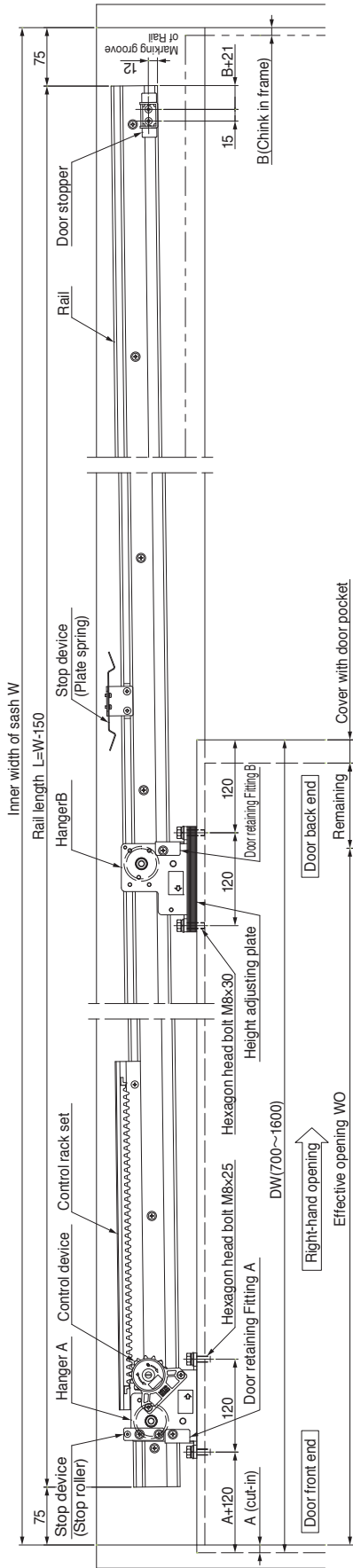


Door width DW [mm]	No. of plate used
600~700 or less	3 pcs.
700~800 or less	5 pcs.
800~900 or less	6 pcs.
900~1000 or less	7 pcs.
1000~1100 or less	8 pcs.
1100~1200 or less	9 pcs.
1200~1300 or less	10 pcs.
1300~1400 or less	12 pcs.
1400~1500 or less	13 pcs.
1500~1600 or less	14 pcs.

Remarks

- These diagrams represent a right-hand opening type. The left-hand opening type is a mirror image of these diagrams.
- Door orientation is right-handed if the door is opened rightwards as viewed from the maintenance panel and left-handed if the door is opened leftwards.



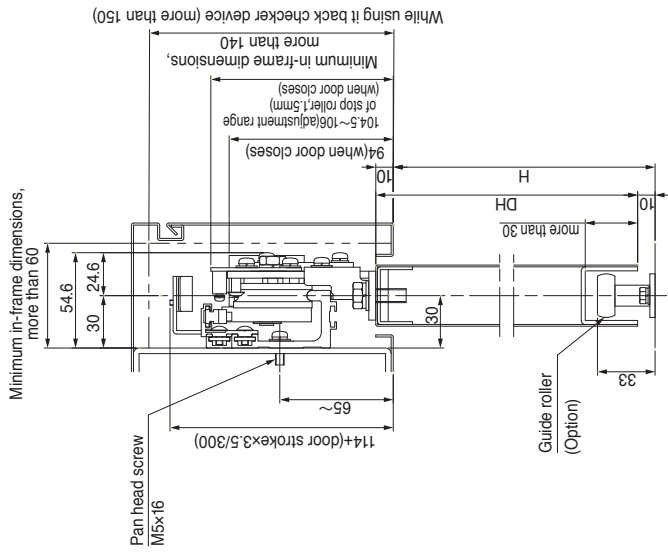


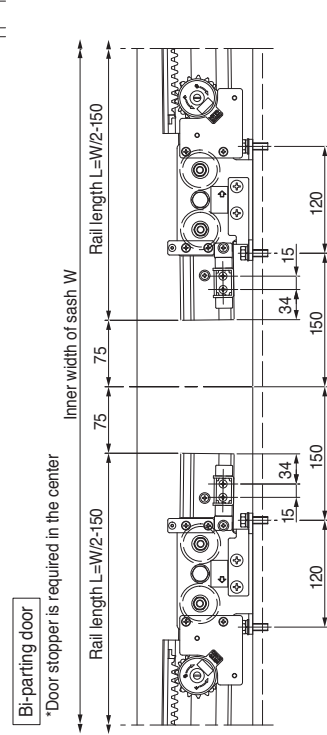
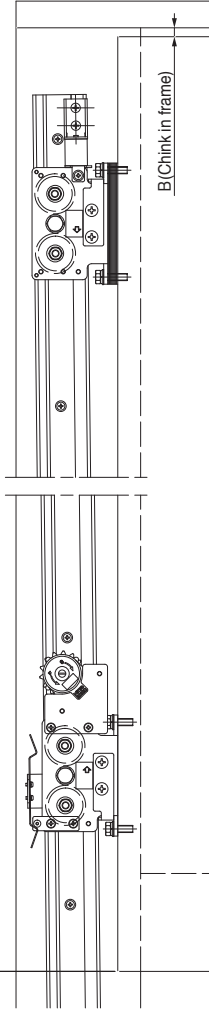
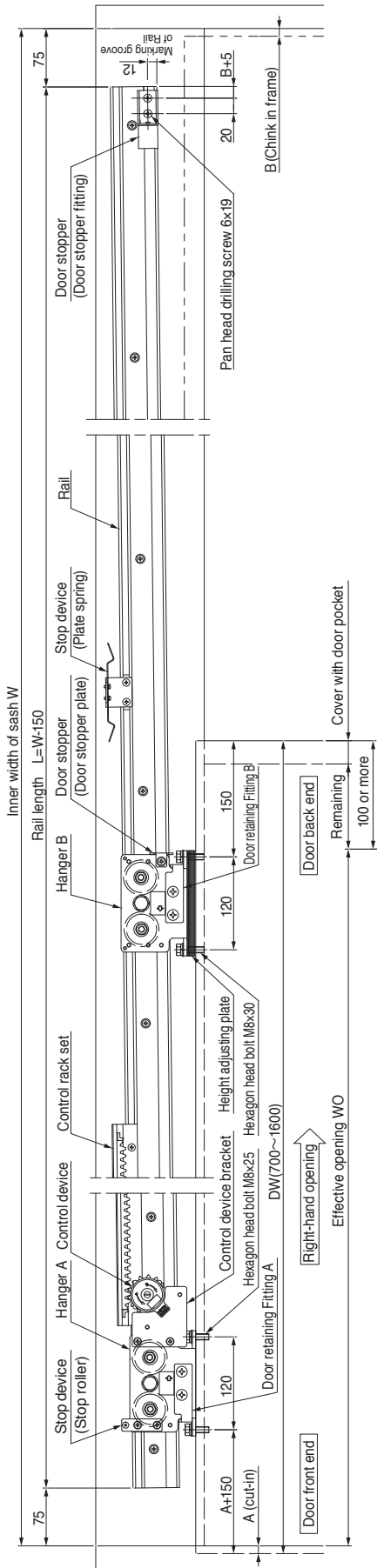
Number of height adjusting plate. (reference)

Door width DW [mm]	No. of plate used
700~800 or less	6 pcs.
800~900 or less	7 pcs.
900~1000 or less	8 pcs.
1000~1100 or less	9 pcs.
1100~1200 or less	10 pcs.
1200~1300 or less	12 pcs.
1300~1400 or less	13 pcs.
1400~1500 or less	14 pcs.
1500~1600 or less	15 pcs.

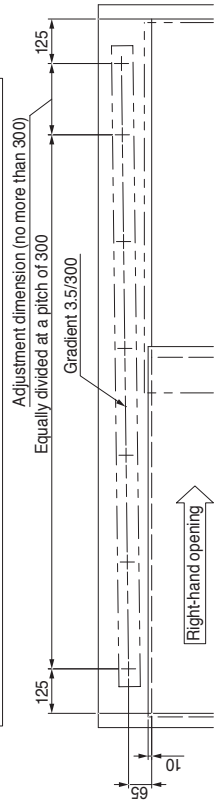
Remarks

- These diagrams represent a right-hand opening type. The left-hand opening type is a mirror image of these diagrams.
- Door orientation is right-handed if the door is opened rightwards as viewed from the maintenance panel and left-handed if the door is opened leftwards.





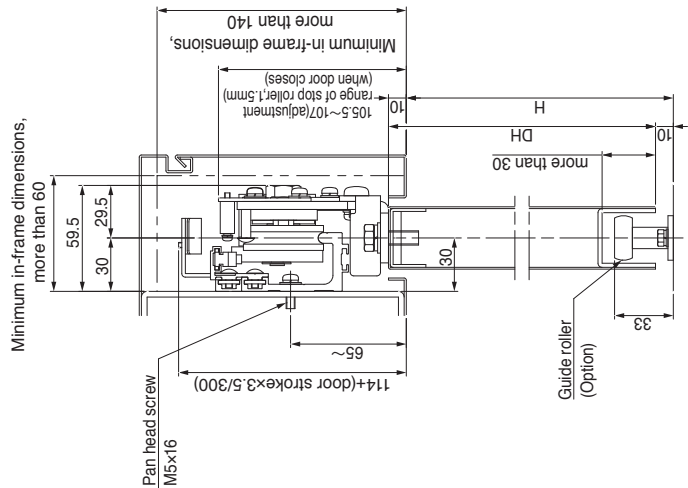
Position diagram for rail-mounting holes (as viewed from inspection panel) M5 (P=0.8)



Number of height adjusting plate. (reference)	
Door width DW [mm]	No. of plate used
700~800 or less	4 pcs.
800~900 or less	5 pcs.
900~1000 or less	6 pcs.
1000~1100 or less	7 pcs.
1100~1200 or less	8 pcs.
1200~1300 or less	10 pcs.
1300~1400 or less	11 pcs.
1400~1500 or less	12 pcs.
1500~1600 or less	13 pcs.

Remarks

- These diagrams represent a right-hand opening type. The left-hand opening type is a mirror image of these diagrams.
- Door orientation is right-handed if the door is opened rightwards as viewed from the maintenance panel and left-handed if the door is opened leftwards.



Highly reliable and cost effective self-closing solution for wooden sliding doors.
Safe & long term operation guaranteed.
Simple to install, set up and use.

Features

- All parts required for horizontal installation on light wooden door (e.g. guide rail, guide roller, stop device, etc.) are included in standard component.
- The product can be used for both left and right hand sliding doors and can be easily converted between left and right by simple adjustment.

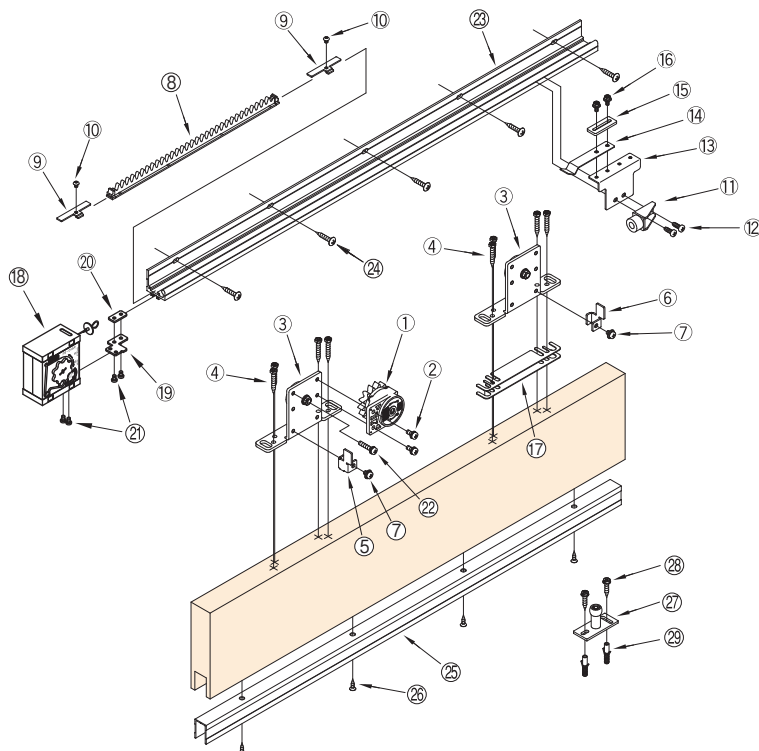


Specifications

right and left handed opening

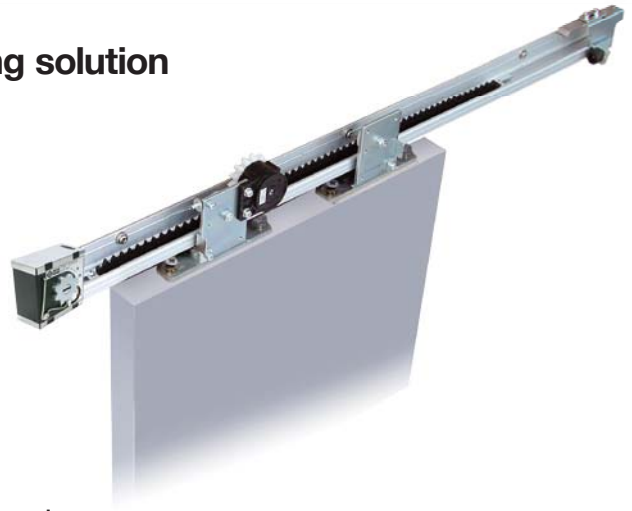
Model		NSC-CW60V-22	NSC-CW60V-31
Applicable doors	Weight [kg]	10-60	
	Width [mm]	600-1,200	1,200-1,600
Max. stroke [mm]		1,500	
Closing drive system		Spiral spring type	
Controlling system		Fluid friction resistance type	
Controlling time		7-11 seconds (with a door-opening distance of 900mm)	
Initial opening force [N]		6.5 (Door weight 10kg), 8.9 (Door weight 60kg)	
Durability		More than half million open/close operations	
Control device		SC-C06V	
Pull spring		PS-04A	
Rail length [m]		2.2	3.1
Guide rail [m]		1.3	1.6

Part details



No.	Part	Q'ty	Remark
①	Control device	1	
②	M5×12 pan head screw	2	For control device
③	Hanger	2	
④	φ5X35 cross recessed hexagon head tapping screw	8	For hanger
⑤	Door retaining fitting Hanger L	1	
⑥	Door retaining fitting Hanger R	1	Door retention
⑦	M5×8 pan head screw	2	
⑧	Control rack	1	
⑨	Control rack fitting	2	For control rack
⑩	M4x5 hexagon socket button head screw	2	
⑪	Door stopper	1	
⑫	5x16 pan head drilling screw	2	For stop device
⑬	Plate spring bracket	1	
⑭	Plate spring	1	For door stopper
⑮	Stop force adjusting plate	1	
⑯	M4X10 cross recessed hexagon head screw	2	
⑰	Height adjusting plate (t = 1.0)	4	
⑱	Pull spring	1	
⑲	Pull spring bracket	1	
⑳	Plate nut	1	For pull spring
㉑	M4×6 pan head screw	4	
㉒	M5×25 pan head screw	1	
㉓	Rail L = 2200 [L = 3100]	1	For rail
㉔	φ5×30 truss head tapping screw	8[11]	
㉕	Guide rail L = 1300 [L = 1600]	1	For guide rail
㉖	φ4x16 countersunk head tapping screw	4[5]	
㉗	φ16 Guide roller	1	
㉘	φ5×25 Hexagon head tapping screw	2	For guide roller
㉙	M5×12 Hexagon head screw	2	
㉚	Fischer plug 6x30	2	

Highly reliable and cost effective self-closing solution for steel sliding doors.
Safe & long term operation guaranteed.
Simple to install, set up and use.



Features

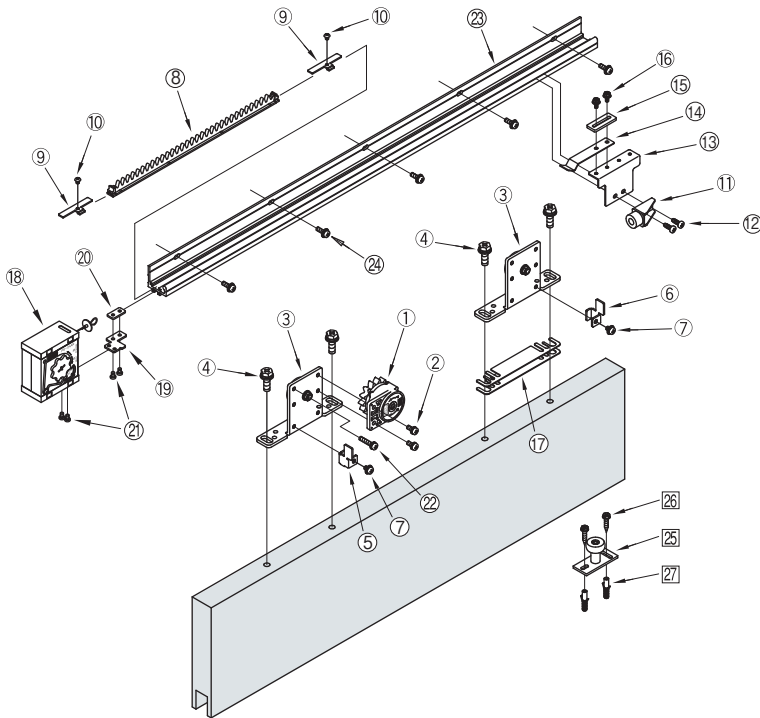
- All parts required for horizontal installation on light steel door (e.g. guide rail, guide roller, stop device, etc.) are included in standard component.
- The product can be used for both left and right hand sliding doors and can be easily converted between left and right by simple adjustment.

Specifications

right and left handed opening

Model		NSC-C60V-22	NSC-C60V-31
Applicable doors	Weight [kg]	10-60	
	Width [mm]	600-1,200	1,200-1,600
Max. stroke [mm]		1,500	
Closing drive system		Spiral spring type	
Controlling system		Fluid friction resistance type	
Controlling time		7-11 seconds (with a door-opening distance of 900mm)	
Initial opening force [N]		6.5 (Door weight 10kg), 8.9 (Door weight 60kg)	
Durability		More than half million open/close operations	
Control device		SC-C06V	
Pull spring		PS-04A	
Rail length [m]		2.2	3.1

Part details

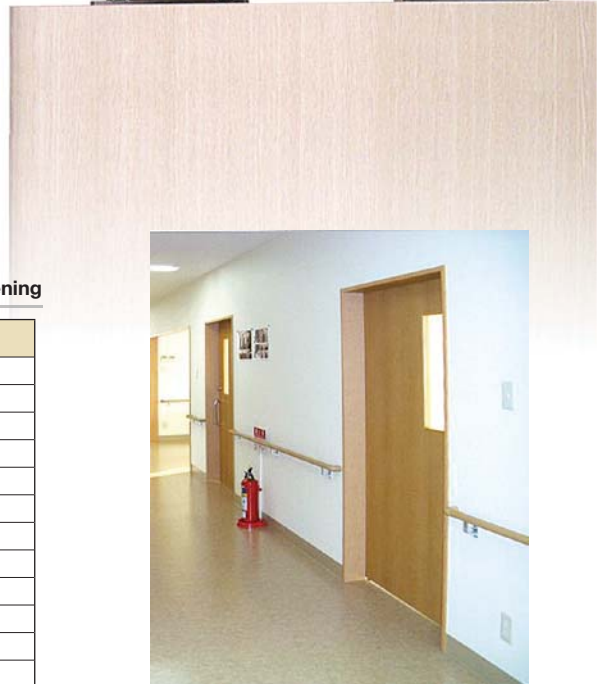


No.	Part	Q'ty	Remark
①	Control device	1	For control device
②	M5×12 pan head screw	2	
③	Hanger	2	For hanger
④	M8×25 cross recessed hexagon head screw	4	
⑤	Door retaining fitting Hanger L	1	Door retention
⑥	Door retaining fitting Hanger R	1	
⑦	M5×8 pan head screw	2	For control rack
⑧	Control rack	1	
⑨	Control rack fitting	2	For stop device
⑩	M4X5 hexagon socket button head screw	2	
⑪	Door stopper	1	For door stopper
⑫	5x16 pan head drilling screw	2	
⑬	Plate spring bracket	1	For pull spring
⑭	Plate spring	1	
⑮	Stop force adjusting plate	1	For rail
⑯	M4X10 cross recessed hexagon head screw	2	
⑰	Height adjusting plate (t = 1.0)	4	For guide roller (Option)
⑱	Pull spring	1	
⑲	Pull spring bracket	1	For Fischer plug
⑳	Plate nut	1	
㉑	M4×6 pan head screw	4	For rail
㉒	M5×25 pan head screw	1	
㉓	Rail L = 2200 [L = 3100]	1	For guide roller (Option)
㉔	M5×16 pan head screw	8[11]	
㉕	Guide roller *	1	For Fischer plug
㉖	φ5×25 Hexagon head tapping screw	2	
㉗	M5×12 Hexagon head screw	2	For Fischer plug
㉘	Fischer plug 6x30	2	

*4 types, φ5, φ25, φ30, φ35

Features

- All parts required for horizontal installation on wooden door (e.g. guide rail, guide roller, stop device, etc.) are included in standard component.
- Lug screws are included for securely installing hangers to door.
- Long life time achieved by endless fluid frictional resistance type braking mechanism.
- The product can be used for both left and right hand sliding doors and can be easily converted between left and right by simple adjustment.

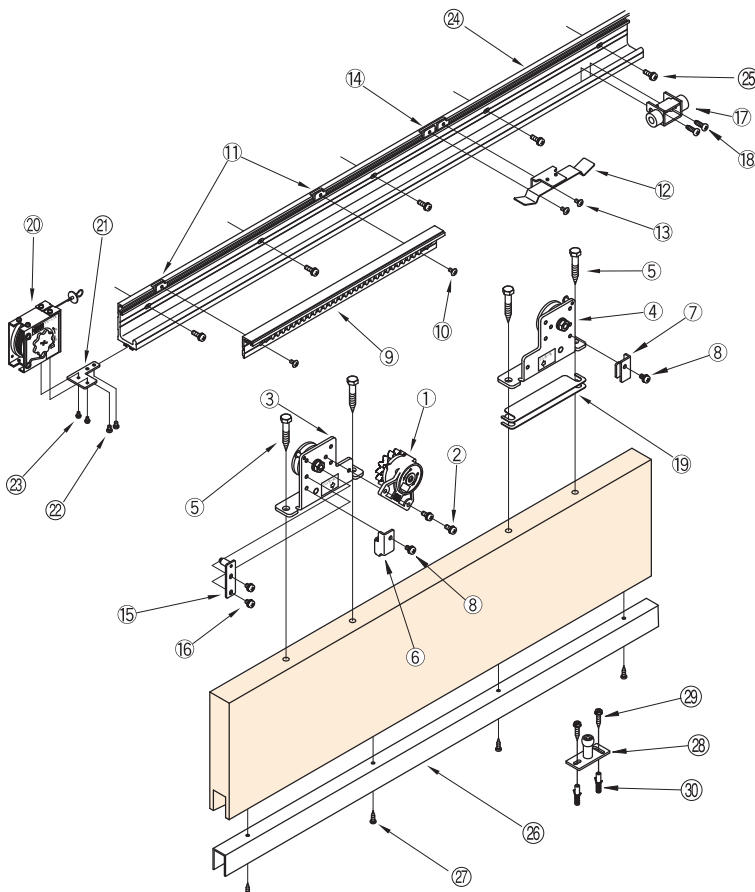


Specifications

right and left handed opening

Model		DSC-CW23-22	DSC-CW23-31
Applicable doors	Weight [kg]	10-30	
	Width [mm]	700-1,200	1,200-1,600
Max. stroke [mm]		1,500	
Closing drive system		Spiral spring type	
Controlling system		Fluid friction resistance type	
Controlling time		7-11 seconds (with a door-opening distance of 900mm)	
Initial opening force [N]		3.5 (Door weight 10kg), 4.6 (Door weight 30kg)	
Durability		More than 1 million open/close operations	
Control device		SC-C03	
Pull spring		PS-02	
Rail length [m]		2.2	3.1
Guide rail [m]		1.3	1.6

Part details



No.	Part	Q'ty	Remark
①	Control device	1	
②	M5×12 pan head screw	2	For control device
③	Hanger A	1	
④	Hanger B	1	For hanger
⑤	φ8X50 hexagon coach screw	4	
⑥	Door retaining fitting Hanger A	1	
⑦	Door retaining fitting Hanger B	1	Door retention
⑧	M5×8 pan head screw	2	
⑨	Control rack set	1	
⑩	M4×8 truss head screw	2	For control rack
⑪	Plate nut	2	
⑫	Plate spring	1	
⑬	M4X8 truss head screw	2	
⑭	Plate nut	2	For stop device
⑮	Stop roller	1	
⑯	M5×8 pan head screw	2	
⑰	Door stopper	1	
⑱	φ5X16 pan head tapping screw	2	For door stopper
⑲	Height adjusting plate (t = 1.0)	4	
⑳	Pull spring	1	
㉑	Pull spring bracket	1	
㉒	M4×5 pan head screw	2	For pull spring
㉓	M3×8 pan head screw	2	
㉔	Rail L = 2200 [L = 3100]	1	
㉕	M5×16 pan head screw	8[11]	For rail
㉖	φ5×30 truss head tapping screw	8[11]	
㉗	Guide rail L = 1300 [L = 1600]	1	For guide rail
㉘	φ4×16 pan head tapping screw	5[6]	
㉙	φ16 Guide roller	1	
㉚	φ5×25 Hexagon head tapping screw	2	For guide roller
㉛	M5×12 Hexagon head screw	2	
㉜	Fischer plug 6x30	2	

Features

- All parts required for horizontal installation on wooden door (e.g. guide rail, guide roller, stop device, etc.) are included in standard component.
- Long life time achieved by endless fluid frictional resistance type braking mechanism.
- The product can be used for both left and right hand sliding doors and can be easily converted between left and right by simple adjustment.
- Quick and easy installation without any special tool.



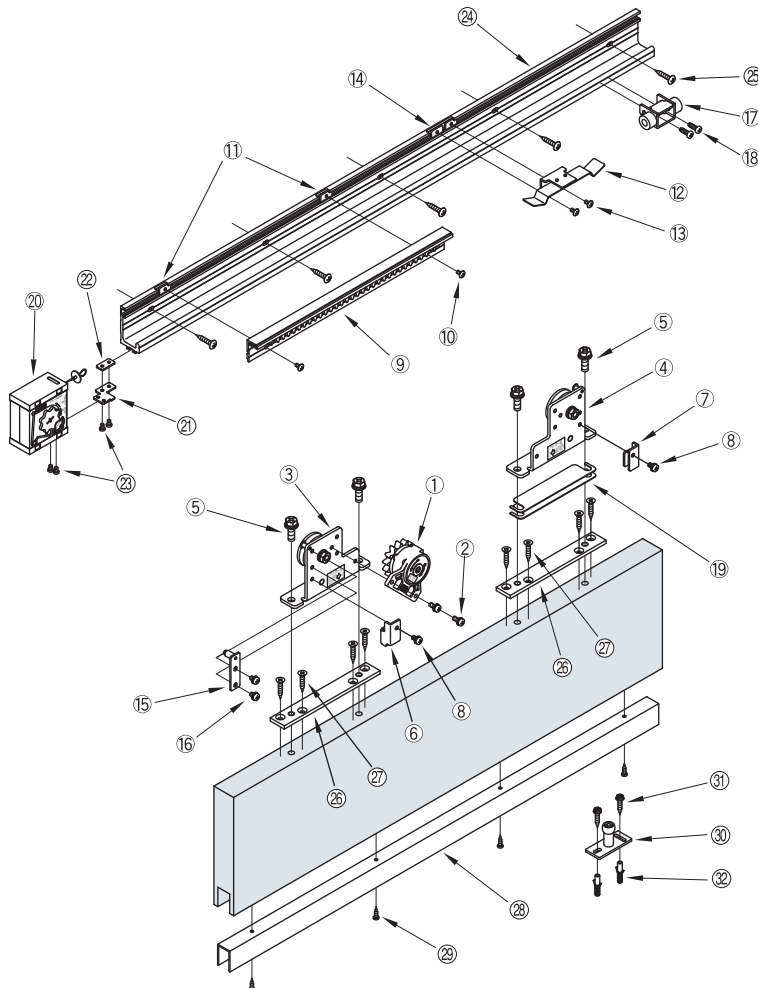
Specifications

right and left handed opening

Model		NSC-CW48-22	NSC-CW48-31
Applicable doors	Weight [kg]	30-80	
	Width [mm]	700-1,200	1,200-1,600
Max. stroke [mm]		1,500	
Closing drive system		Spiral spring type	
Controlling system		Fluid friction resistance type	
Controlling time		7-11 seconds (with a door-opening distance of 900mm)	
Initial opening force [N]		6.6 (Door weight 30kg), 9.2 (Door weight 80kg)	
Durability		More than 1 million open/close operations	
Control device		SC-C08	
Pull spring		PS-04A	
Rail length [m]		2.2	3.1
Guide rail [m]		1.3	1.6



Part details



No.	Part	Q'ty	Remark
①	Control device	1	
②	M5×12 pan head screw	2	For control device
③	Hanger A	1	
④	Hanger B	1	For hanger
⑤	M8×25 hexagon head bolt	4	
⑥	Door retaining fitting Hanger A	1	
⑦	Door retaining fitting Hanger B	1	Door retention
⑧	M5×8 pan head screw	2	
⑨	Control rack set	1	
⑩	M4×8 truss head screw	2	For control rack
⑪	Plate nut	2	
⑫	Plate spring	1	
⑬	M4X8 truss head screw	2	
⑭	Plate nut	2	For stop device
⑮	Stop roller	1	
⑯	M5×8 pan head screw	2	
⑰	Door stopper	1	
⑱	φ5X16 pan head tapping screw	2	For door stopper
⑲	Height adjusting plate (t = 1.0)	4	
⑳	Pull spring	1	
㉑	Pull spring bracket	1	
㉒	Plate nut	1	For pull spring
㉓	M4×6 pan head screw	4	
㉔	Rail L = 2200 [L = 3100]	1	
㉕	M5×16 pan head screw	8[11]	For rail
㉖	φ5×30 truss head tapping screw	8[11]	
㉗	Wooden door plate	2	
㉘	φ5×30 countersunk head tapping screw	8	
㉙	Guide rail L = 1300 [L = 1600]	1	
㉚	φ4X16 pan head tapping screw	5[6]	For guide rail
㉛	φ16 Guide roller	1	
㉜	φ5×25 Hexagon head tapping screw	2	For guide roller
㉝	M5×12 Hexagon head screw	2	
㉞	Fischer plug 6x30	2	

Features

- All parts required for horizontal installation on steel door (e.g. guide rail, guide roller, stop device, etc.) are included in standard component.
- Long life time achieved by endless fluid frictional resistance type braking mechanism.
- The product can be used for both left and right hand sliding doors and can be easily converted between left and right by simple adjustment.
- Quick and easy installation without any special tool.



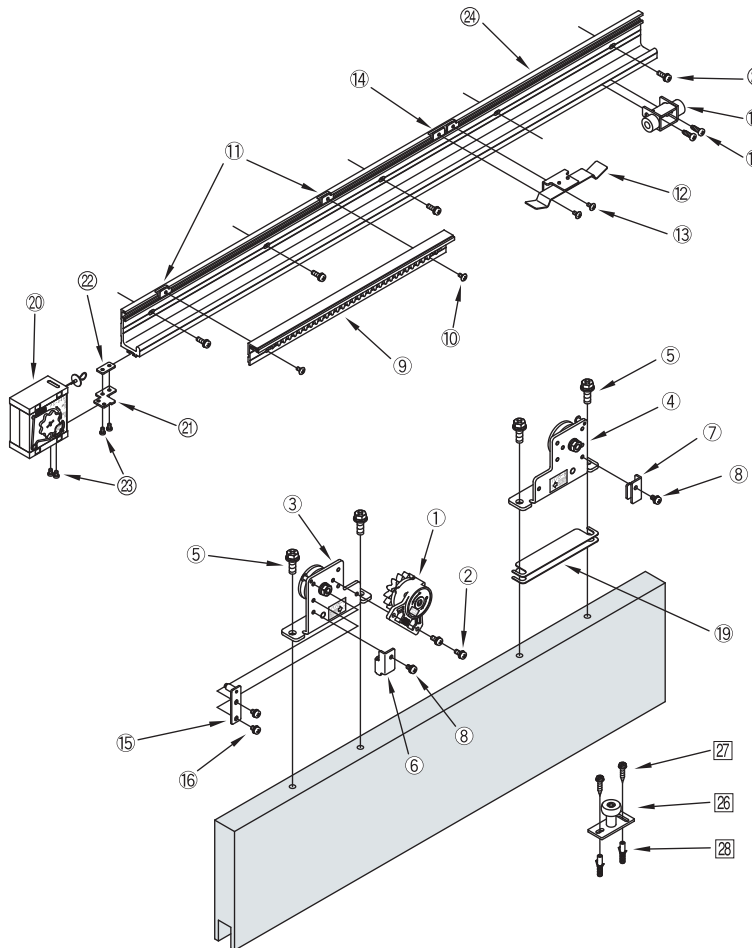
Specifications

right and left handed opening

Model		NSC-C48-22	NSC-C48-31
Applicable doors	Weight [kg]	10-80	
	Width [mm]	700-1,200	1,200-1,600
Max. stroke [mm]		1,500	
Closing drive system		Spiral spring type	
Controlling system		Fluid friction resistance type	
Controlling time		7-11 seconds (with a door-opening distance of 900mm)	
Initial opening force [N]		5.5 (Door weight 10kg), 9.2 (Door weight 80kg)	
Durability		More than 1 million open/close operations	
Control device		SC-C08	
Pull spring		PS-04A	
Rail length [m]		2.2	3.1



Part details



No.	Part	Q'ty	Remark
①	Control device	1	
②	M5×12 pan head screw	2	For control device
③	Hanger A	1	
④	Hanger B	1	For hanger
⑤	M8×25 cross recessed hexagon head bolt	4	
⑥	Door retaining fitting Hanger A	1	
⑦	Door retaining fitting Hanger B	1	Door retention
⑧	M5×8 pan head screw	2	
⑨	Control rack set	1	
⑩	M4×8 truss head screw	2	For control rack
⑪	Plate nut	2	
⑫	Plate spring	1	
⑬	M4×8 truss head screw	2	
⑭	Plate nut	2	For stop device
⑮	Stop roller	1	
⑯	M5×8 pan head screw	2	
⑰	Door stopper	1	
⑱	φ5X16 pan head tapping screw	2	For door stopper
⑲	Height adjusting plate (t = 1.0)	4	
⑳	Pull spring	1	
㉑	Pull spring bracket	1	
㉒	Plate nut	1	For pull spring
㉓	M4×6 pan head screw	4	
㉔	Rail L = 2200 [L = 3100]	1	
㉕	M5×16 pan head screw	8[11]	For rail
㉖	φ5×30 truss head tapping screw	8[11]	
㉗	φ16 Guide roller *	1	
㉘	φ5×25 Hexagon head tapping screw	2	For guide roller (Option)
㉙	M5×12 Hexagon head screw	2	
㉚	Fischer plug 6x30	2	

*4 types, φ16, φ25, φ30, φ35

Features

- By adopting stainless steel material and secure seal structure, the product can be used for a long time in a high humidity environment such as a bathroom.
- Long life time achieved by endless fluid frictional resistance type braking mechanism.
- The product can be used for both left and right hand sliding doors and can be easily converted between left and right by simple adjustment.

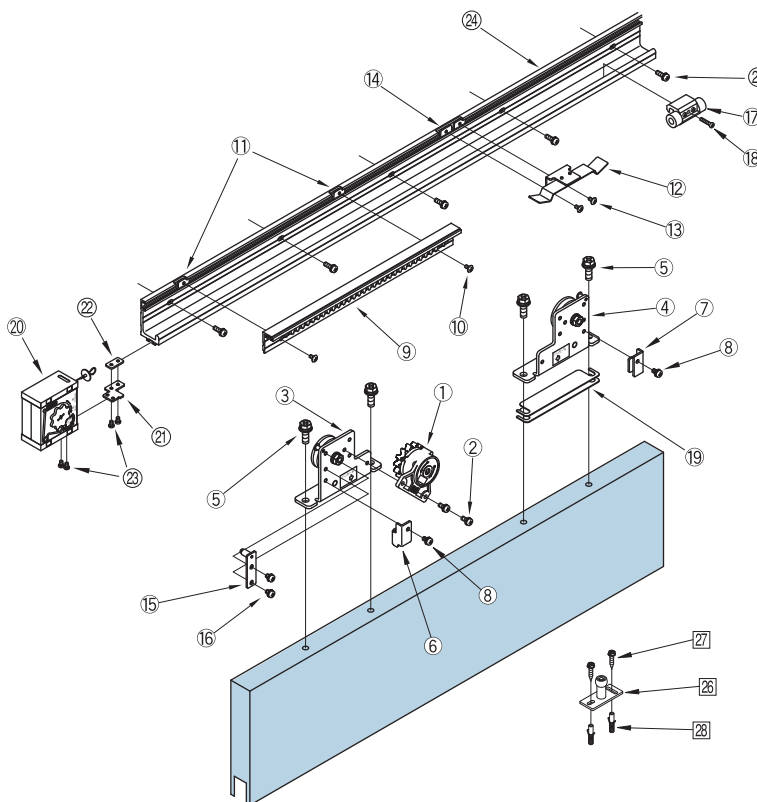
Specifications

right and left handed opening

Model		NSC-CB48-22	NSC-CB48-31
Applicable doors	Weight [kg]	10-80	
	Width [mm]	700-1,200	1,200-1,600
Max. stroke [mm]		1,500	
Closing drive system		Spiral spring type	
Controlling system		Fluid friction resistance type	
Controlling time		7-11 seconds (with a door-opening distance of 900mm)	
Initial opening force [N]		5.5 (Door weight 10kg), 9.2 (Door weight 80kg)	
Durability		More than 1 million open/close operations	
Control device		SC-CB08	
Pull spring		PS-B04A	
Rail length [m]		2.2	3.1



Part details



No.	Part	Q'ty	Remark
①	Control device	1	For control device
②	M5×12 pan head screw	2	
③	Hanger A	1	For hanger
④	Hanger B	1	
⑤	M8×25 cross recessed hexagon head bolt	4	Door retention
⑥	Door retaining fitting Hanger A	1	
⑦	Door retaining fitting Hanger B	1	For stop device
⑧	M5×8 pan head screw	2	
⑨	Control rack set	1	For control rack
⑩	M4×8 truss head screw	2	
⑪	Plate nut	2	For stop device
⑫	Plate spring	1	
⑬	M4×8 truss head screw	2	For door stopper
⑭	Plate nut	2	
⑮	Stop roller	1	For door stopper
⑯	M5×8 pan head screw	2	
⑰	Door stopper	1	For pull spring
⑱	Height adjusting plate (t = 1.0)	4	
⑳	Pull spring	1	For rail
㉑	Pull spring bracket	1	
㉒	Plate nut	1	For rail
㉓	M4×6 pan head screw	4	
㉔	Rail L = 2200 [L = 3100]	1	For rail
㉕	M5×16 pan head screw	8[11]	
㉖	φ5×30 truss head tapping screw	8[11]	For guide roller (Option)
㉗	φ16 Guide roller *	1	
㉘	φ5×25 Hexagon head tapping screw	2	For guide roller (Option)
㉙	M5×12 Hexagon head screw	2	
㉚	Fischer plug 6×30	2	

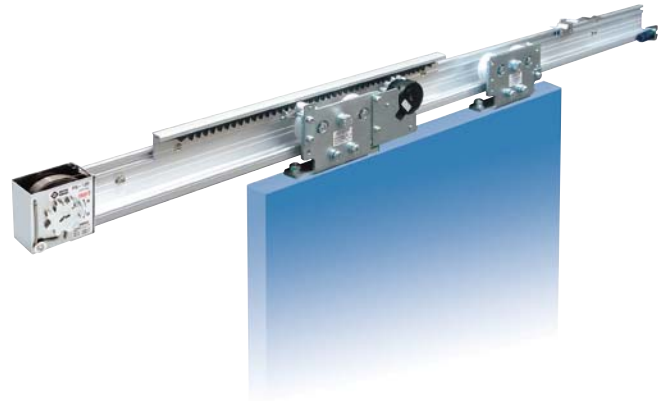
*4 types, φ16, φ25, φ30, φ35

•High Corrosion proof evaluation

	Appearance of control device and hanger	Appearance of pull spring	
NSC-CB type			<p>Rust becomes a problem when these products are used in bathrooms. The use of stainless steel makes these products dramatically more corrosion proof.</p> <p>Test method : CASS test (JIS H 8502) This test evaluates corrosion of specimens by adding small quantities of acetic acid and copper (II) chloride (cupric chloride) to a solution of sodium chloride used in a salt spray test, thus increasing the specimens resistance to corrosion. This method is used mainly to evaluate the corrosion of automotive parts and other plated products. A corrosion test in acid environments is greater than salt spray tests. 48 hour × 3 times (144 hours in total)</p>
Our standard product			

Features

- All parts required for horizontal installation on heavy steel door (e.g. guide rail, guide roller, stop device, etc.) are included in standard component.
- Long life time achieved by endless fluid frictional resistance type braking mechanism.
- Adopting longer control rack, the damper (braking) range has become 1.5 times wider than conventional model.
- The product can be used for both left and right hand sliding doors and can be easily converted between left and right by simple adjustment.
- Quick and easy installation without any special tool.

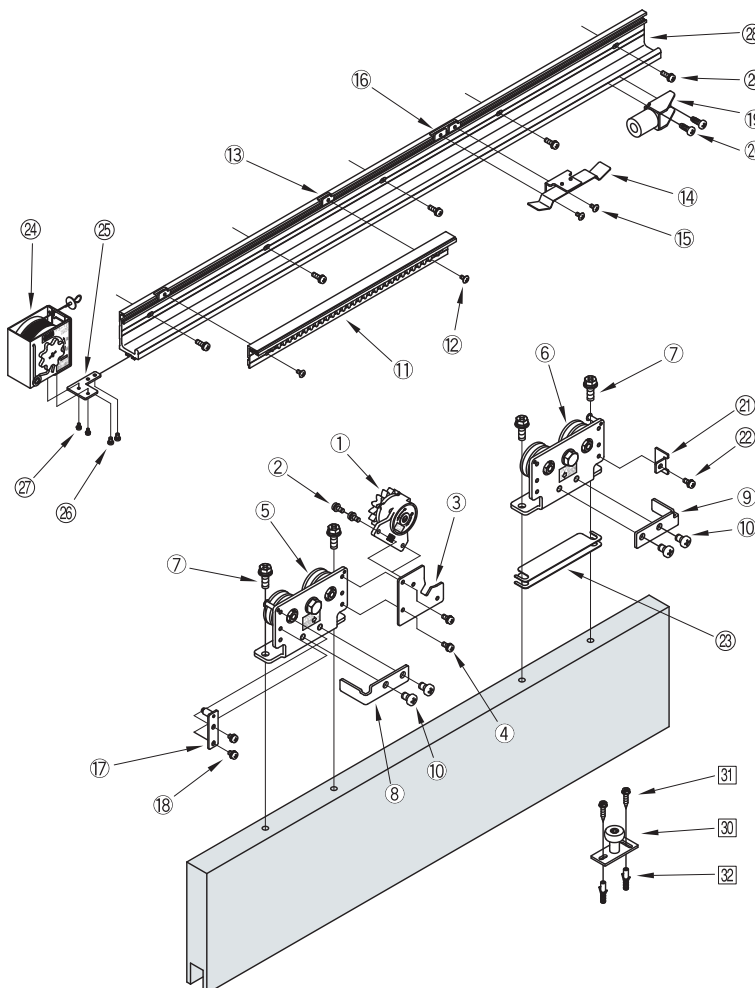


Specifications

right and left handed opening

Model		NSC-C1215-22	NSC-C1215-31
Applicable doors	Weight [kg]	80-150	
	Width [mm]	700-1,200	1,200-1,600
Max. stroke [mm]		1,500	
Closing drive system		Spiral spring type	
Controlling system		Fluid friction resistance type	
Controlling time		7-11 seconds (with a door-opening distance of 900mm)	
Initial opening force [N]		15.5 (Door weight 80kg), 19.2 (Door weight 150kg)	
Durability		More than 1 million open/close operations	
Control device		SC-C15	
Pull spring		PS-12	
Rail length [m]		2.2	3.1

Part details



No.	Part	Q'ty	Remark
①	Control device	1	For control device
②	M5×12 pan head screw	2	
③	Control device bracket	1	
④	M5×12 pan head screw	2	
⑤	Hanger A	1	For hanger
⑥	Hanger B	1	
⑦	M8×25 cross recessed hexagon head bolt	4	Door retention
⑧	Door retaining fitting Hanger A	1	
⑨	Door retaining fitting Hanger B	1	
⑩	M8×12 pan head screw	4	For control rack
⑪	Control rack set	1	
⑫	M4×8 truss head screw	2	
⑬	Plate nut	2	
⑭	Plate spring	1	For door stopper
⑮	M4×8 truss head screw	2	
⑯	Plate nut	2	
⑰	Stop roller	1	
⑱	M5×8 pan head screw	2	For stop device
⑲	Door stopper	1	
⑳	φ6×19 Pan head drilling screw	2	
㉑	Door stopper bearing plate	1	
㉒	M5×8 pan head screw	1	For pull spring
㉓	Height adjusting plate (t = 1.0)	4	
㉔	Pull spring	1	
㉕	Pull spring bracket	1	
㉖	M4×5 pan head screw	2	For rail
㉗	M3×8 pan head screw	2	
㉘	Rail L = 2200 [L = 3100]	1	
㉙	M5×16 pan head screw	8[11]	
㉚	φ5×30 truss head tapping screw	8[11]	For guide roller (Option)
㉛	φ16 Guide roller *	1	
㉜	φ5×25 Hexagon head tapping screw	2	
㉝	M5×12 Hexagon head screw	2	
㉞	Fischer plug 6×30	2	

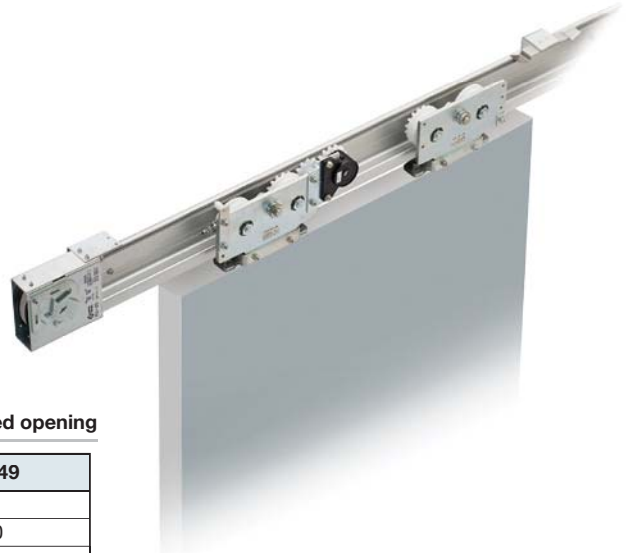
*4 types, φ16, φ25, φ30, φ35

For very heavy steel doors, horizontal type
 Door weight : 150-250kg

NSC-C2525

Features

- All-range brake (damper) system ensures safe and reliable door closing control, preventing slamming against the door frame, finger pinching etc. (PAT.P)
- The product can be used for both left and right hand sliding doors and can be easily converted between left and right by simple adjustment.
- 155mm(H) x 75mm(D) required space in frame - Compact and slim design offers space-saving ideas and cost efficiency.

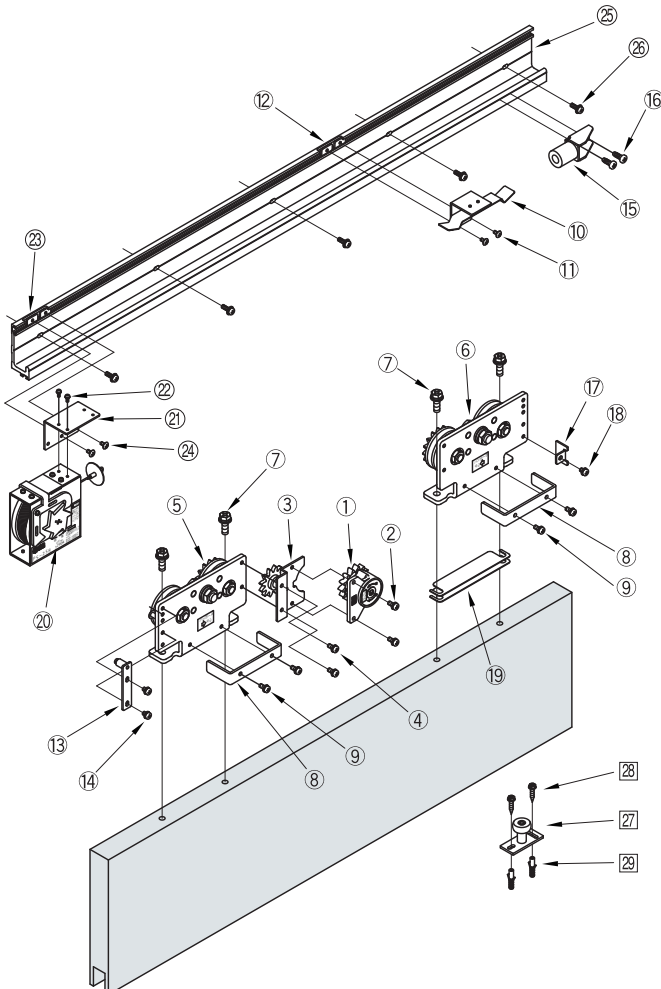


Specifications

right and left handed opening

Model		NSC-C2525-31	NSC-C2525-49
Applicable doors	Weight [kg]	150-250	
	Width [mm]	900-1,600	1,600-2,500
Max. stroke [mm]		2,400	
Closing drive system		Spiral spring type	
Controlling system		Fluid friction resistance type	
Controlling time		7-11 seconds (with a door-opening distance of 900mm)	
Initial opening force [N]		31.4 (Door weight 150kg), 36.5 (Door weight 250kg)	
Durability		More than 200 thousand open/close operations	
Control device		SC-C25	
Pull spring		PS-25	
Rail length [m]		3.1	4.9

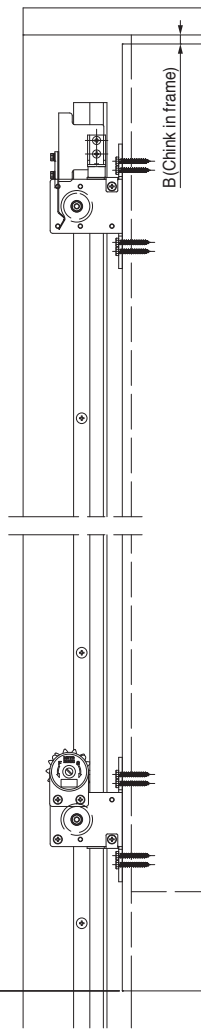
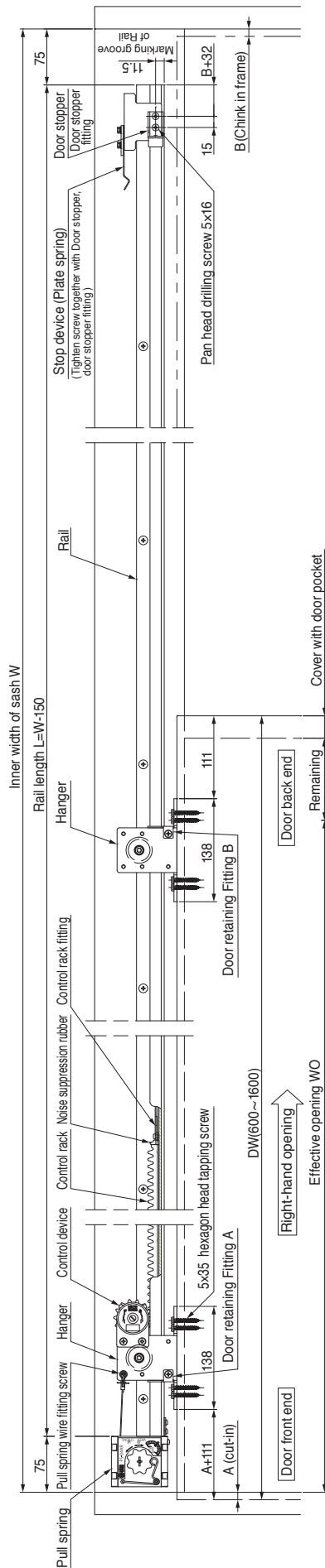
Part details



No.	Part	Q'ty	Remark
①	Control device	1	For control device
②	M5×12 pan head screw	2	
③	Control device bracket	1	
④	M5×12 pan head screw	2	
⑤	Hanger A	1	For hanger
⑥	Hanger B	1	
⑦	M8×25 hexagon head bolt	4	
⑧	Door retaining fitting Hanger	2	Door retention
⑨	M5×12 pan head screw	4	
⑩	Plate spring	1	For stop device
⑪	M4×8 truss head screw	2	
⑫	Plate nut	2	
⑬	Stop roller	1	For door stopper
⑭	M5×8 pan head screw	2	
⑮	Door stopper	1	
⑯	φ6×19 pan head drilling screw	2	For door stopper
⑰	Door stopper bearing plate	1	
⑱	M5×8 pan head screw	1	For pull spring
⑲	Height adjusting plate (t = 1.0)	4	
⑳	Pull spring	1	
㉑	Pull spring bracket	1	
㉒	M3×8 pan head screw	2	For pull spring
㉓	Plate nut	2	
㉔	M4×8 pan head screw	2	For rail
㉕	Rail L = 3100 [L = 4900]	1	
㉖	M5×16 pan head screw	11[17]	
㉗	Guide roller *	1	
㉘	φ5×25 Hexagon head tapping screw	2	For guide roller (Option)
㉙	M5×12 Hexagon head screw	2	
㉚	Fischer plug 6X30	2	

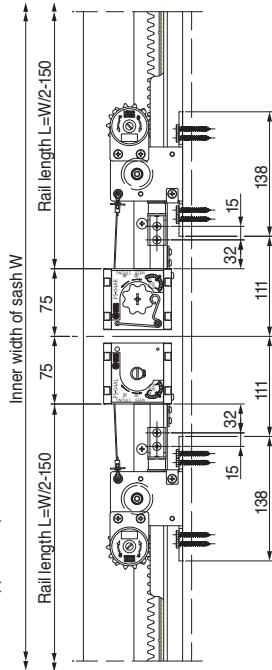
*4 types, φ16, φ25, φ30, φ35

NSC-CW60V



Bi-parting door

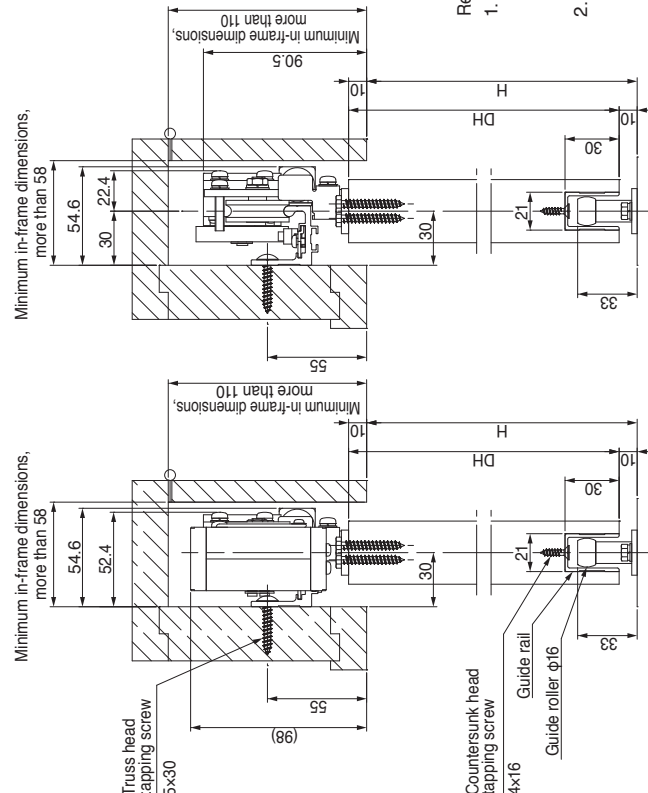
*Door stopper is required in the center

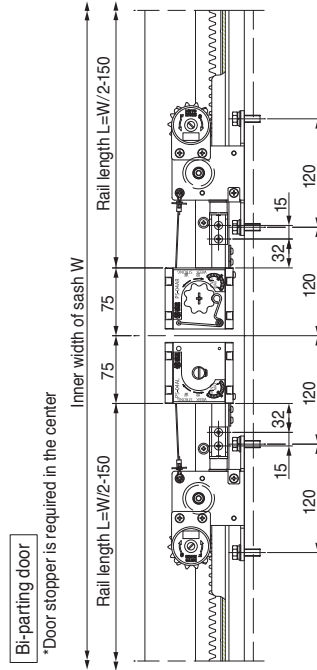
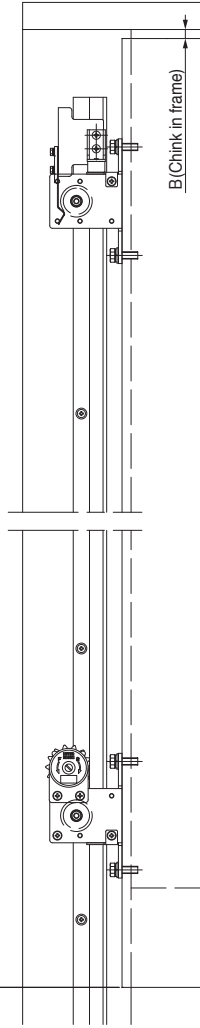
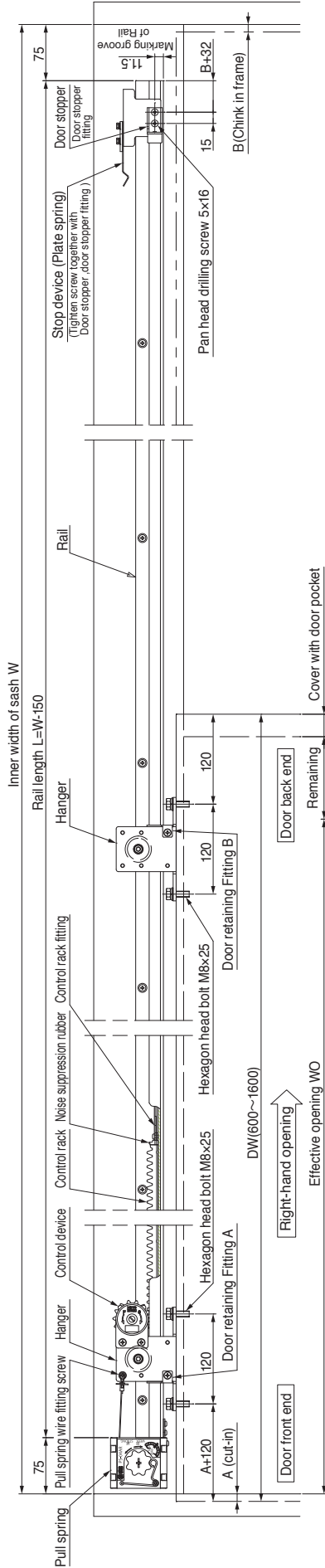


Position diagram for rail-mounting holes (as viewed from inspection panel) M5 (P=0.8)

Remarks

1. These diagrams represent a right-hand opening type. The left-hand opening type is a mirror image of these diagrams.
2. Door orientation is right-handed if the door is opened rightwards as viewed from the maintenance panel and left-handed if the door is opened leftwards.

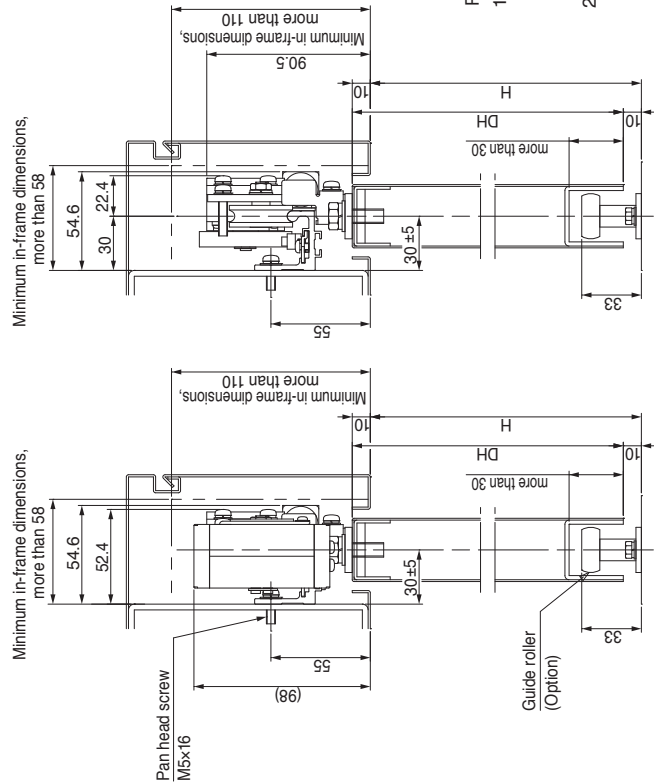




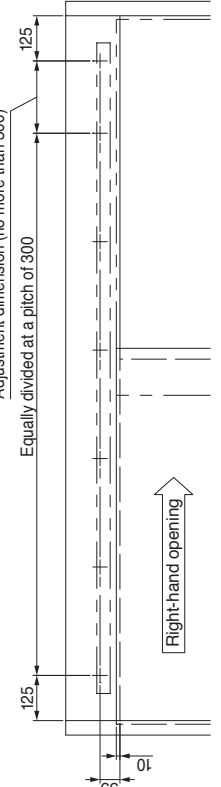
Position diagram for rail-mounting holes (as viewed from inspection panel) M5 (P=0.8)

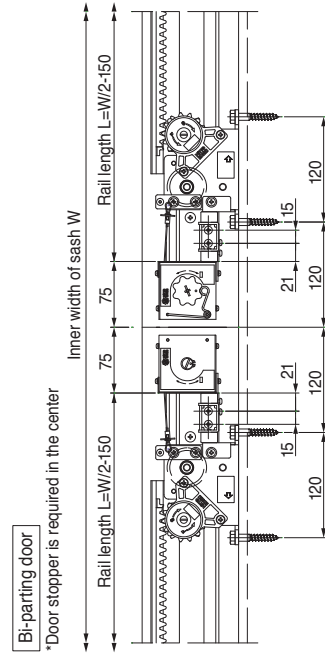
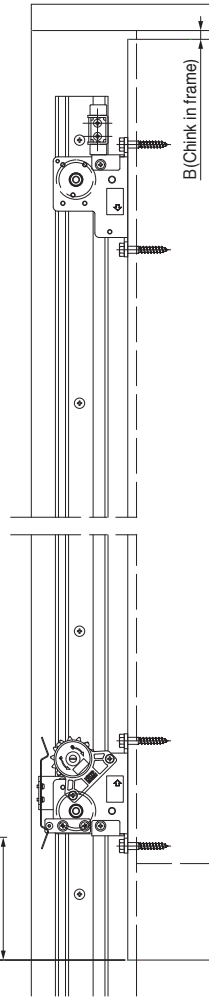
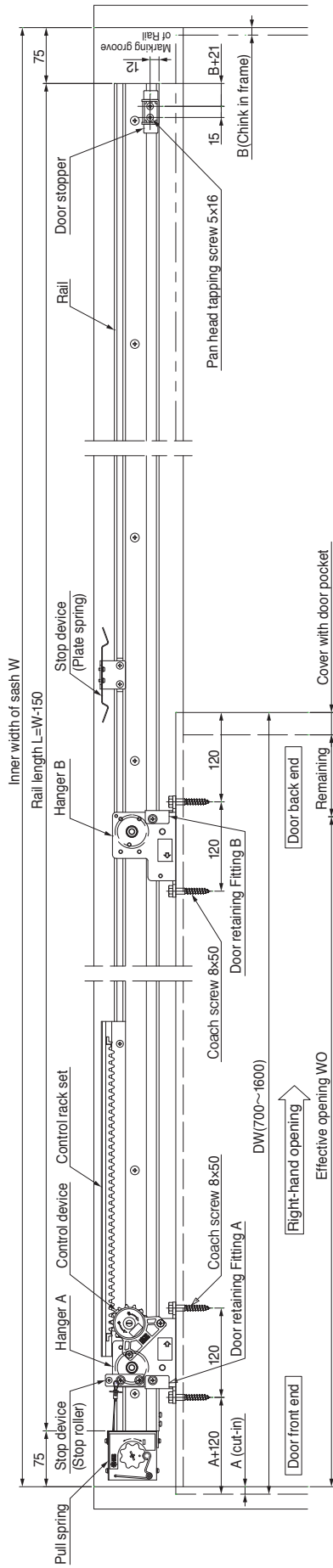
Remarks

1. These diagrams represent a right-hand opening type. The left-hand opening type is a mirror image of these diagrams.
2. Door orientation is right-handed if the door is opened rightwards as viewed from the maintenance panel and left-handed if the door is opened leftwards.

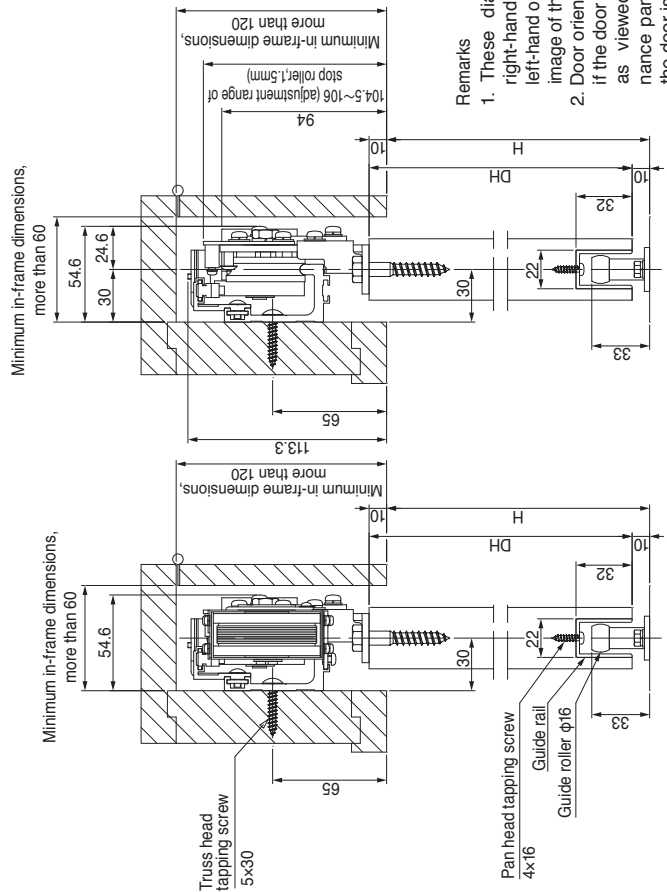
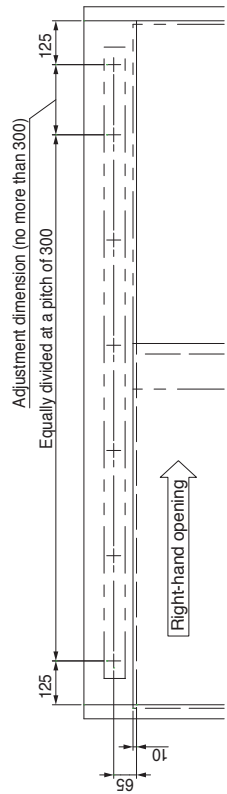


Adjustment dimension (no more than 300)
Equally divided at a pitch of 300



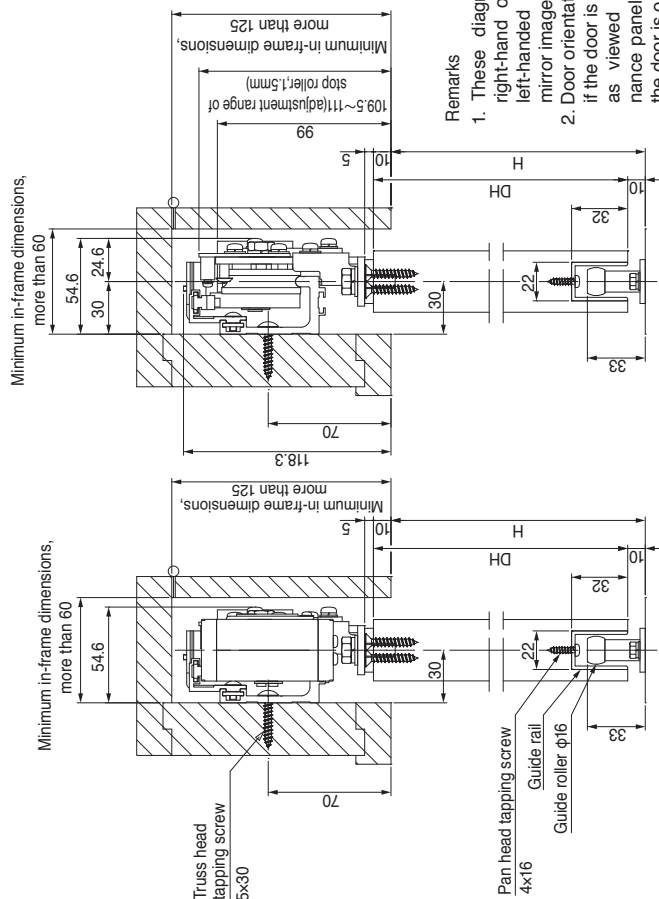
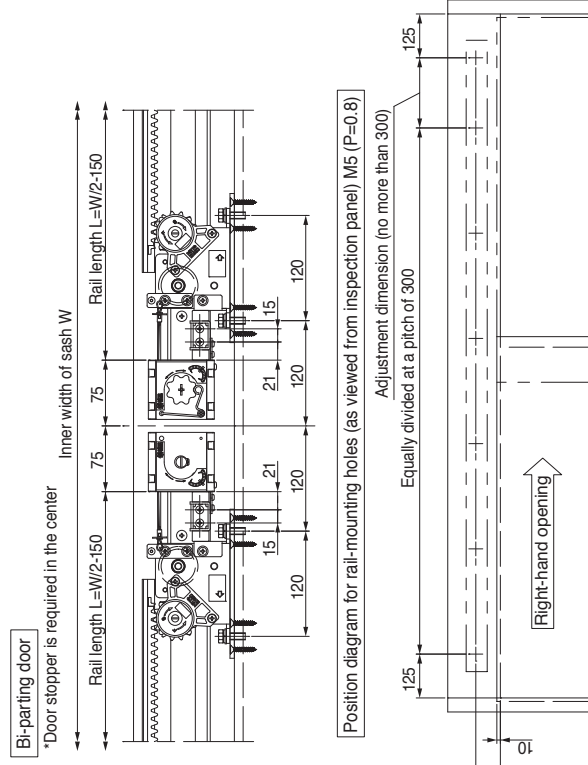
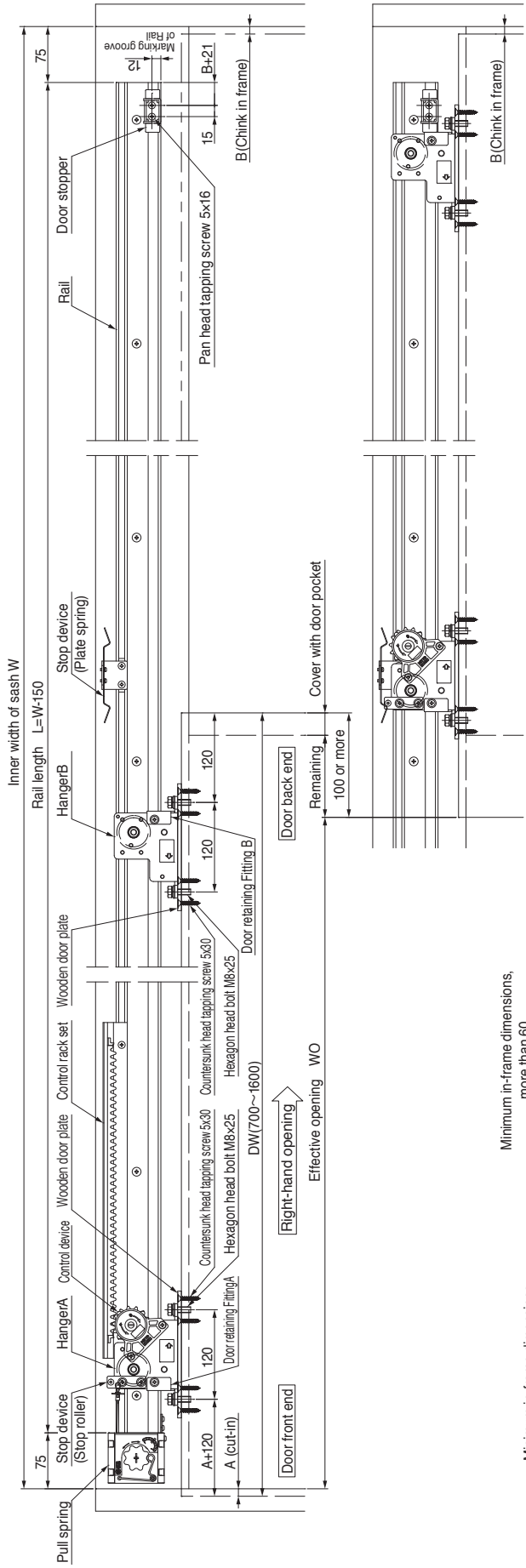


Position diagram for rail-mounting holes (as viewed from inspection panel) M5 (P=0.8)

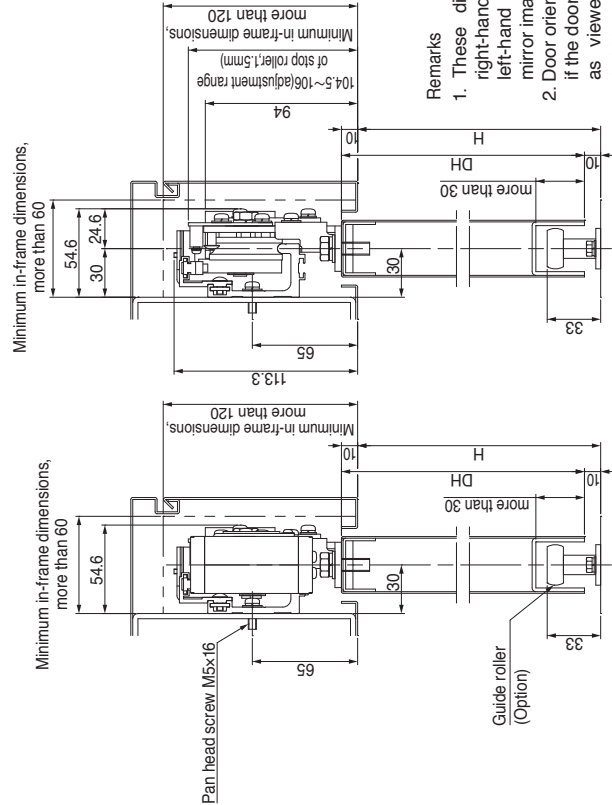
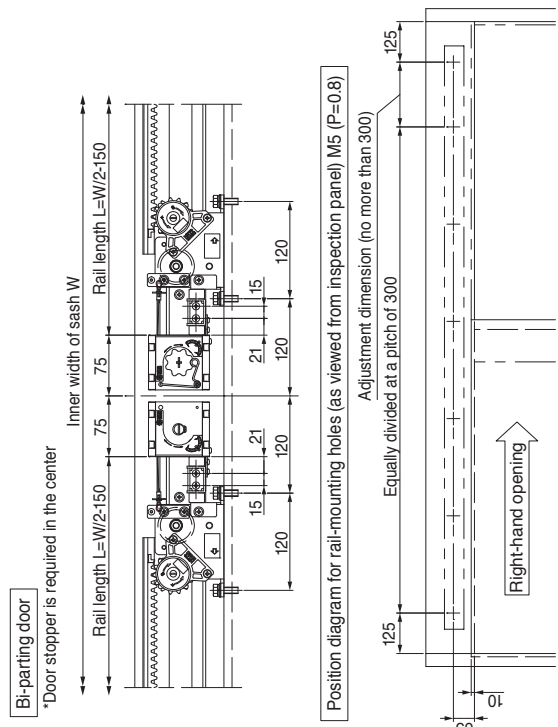
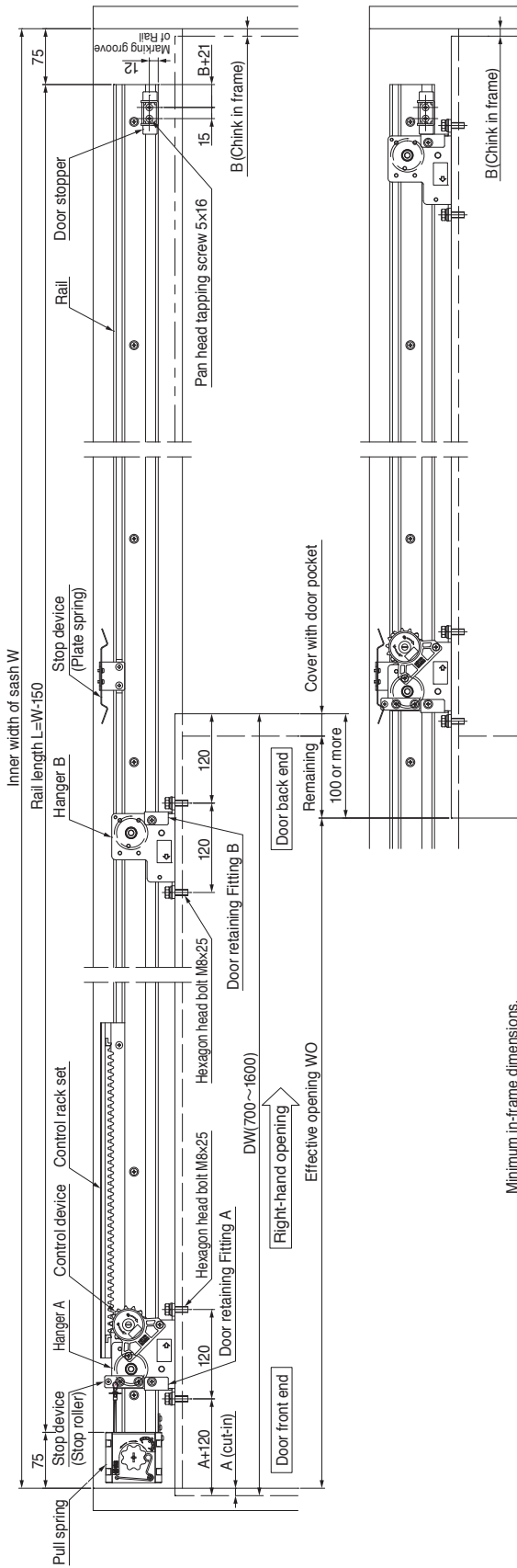


Remarks

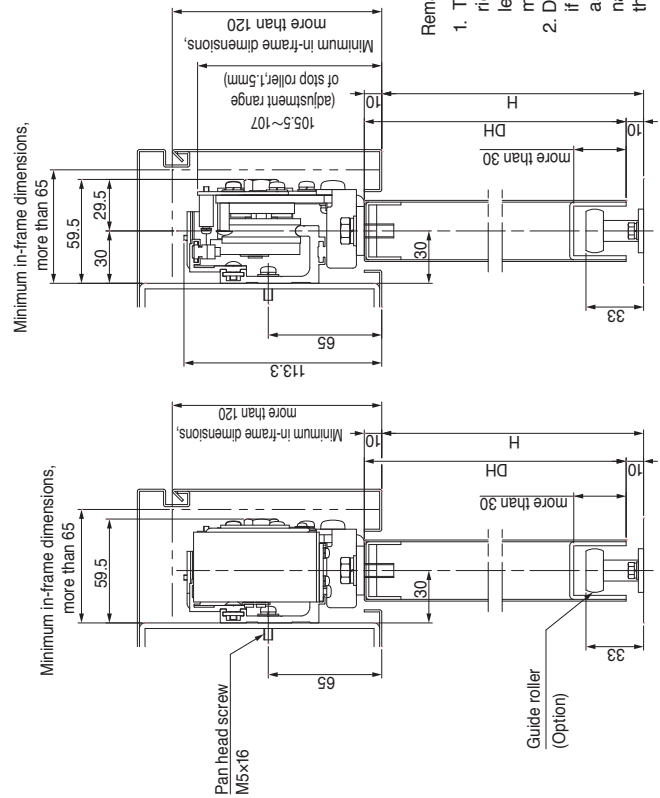
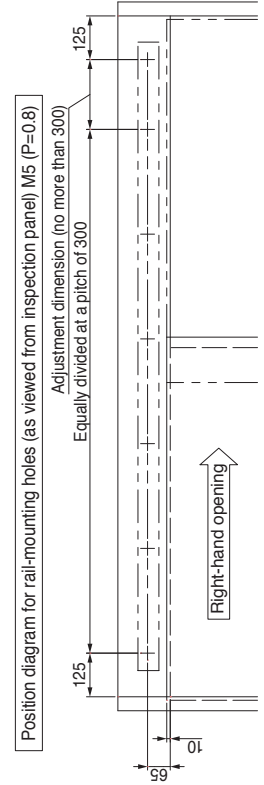
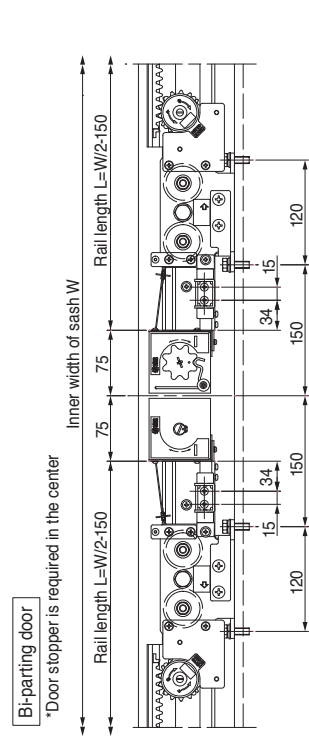
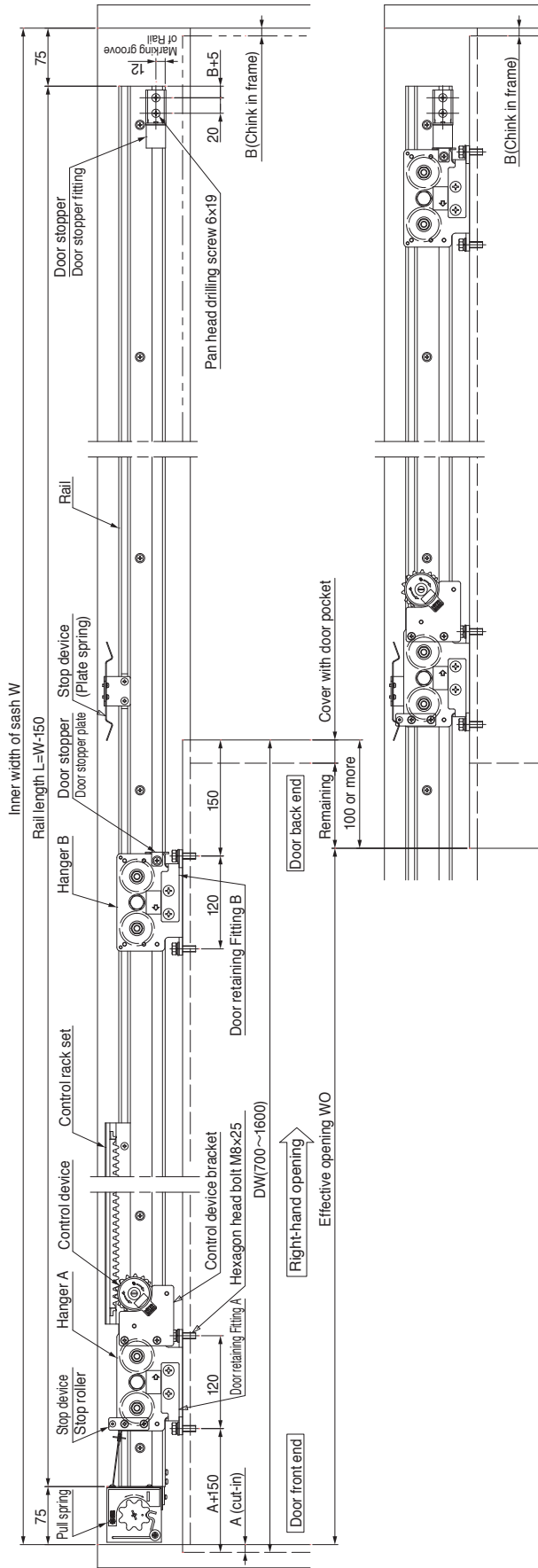
1. These diagrams represent a right-hand opening type. The left-hand opening type is a mirror image of these diagrams.
2. Door orientation is right-handed if the door is opened rightwards as viewed from the maintenance panel and left-handed if the door is opened leftwards.



Remarks
1. These diagrams represent a right-hand opening type. The left-handed opening type is a mirror image of these diagrams.
2. Door orientation is right-handed if the door is opened rightwards as viewed from the maintenance panel and left-handed if the door is opened leftwards.

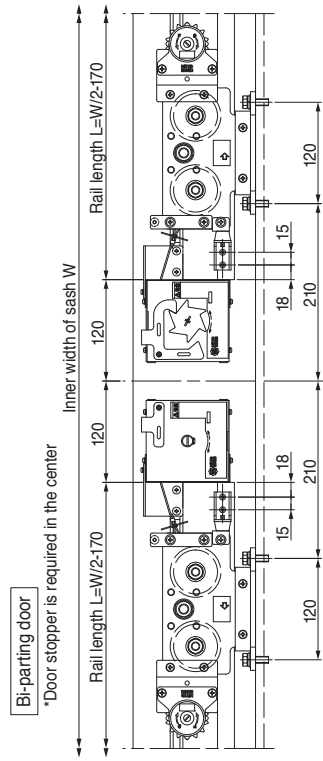
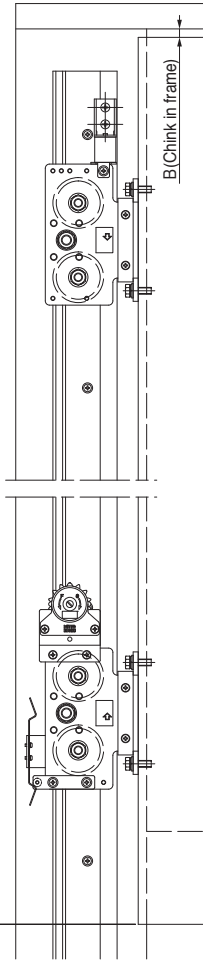
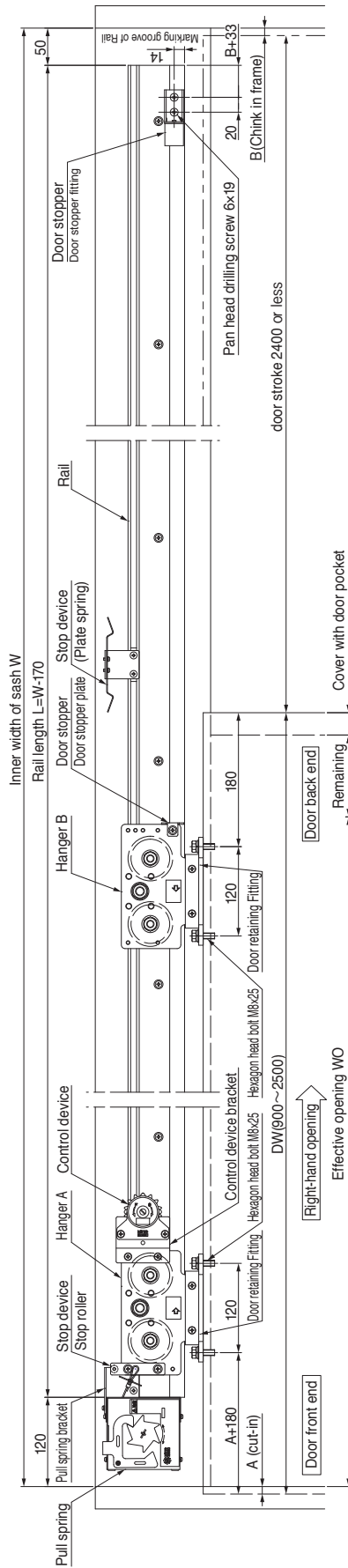


Remarks
 1. These diagrams represent a right-hand opening type. The left-hand opening type is a mirror image of these diagrams.
 2. Door orientation is right-handed if the door is opened rightwards as viewed from the maintenance panel and left-handed if the door is opened leftwards.

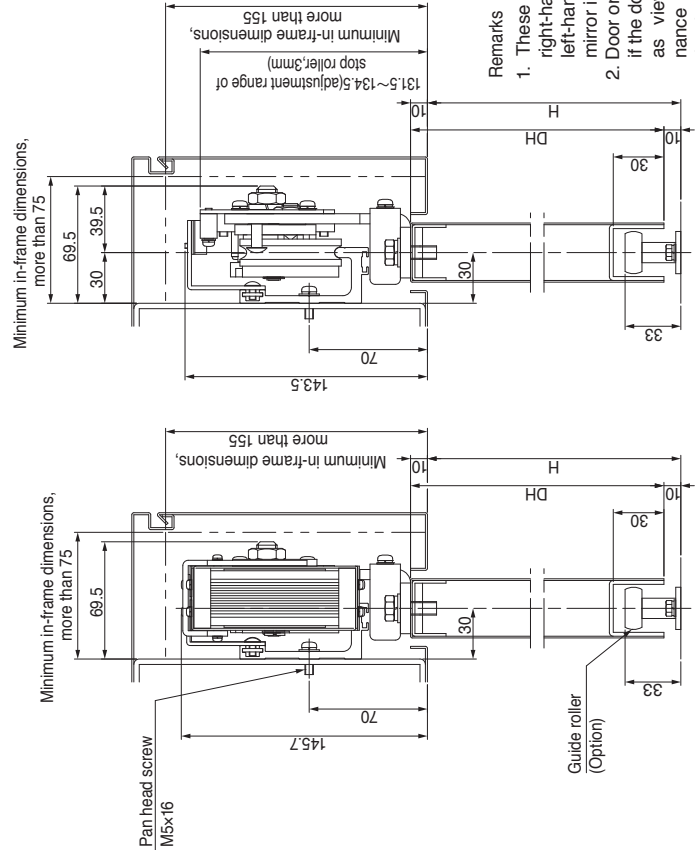
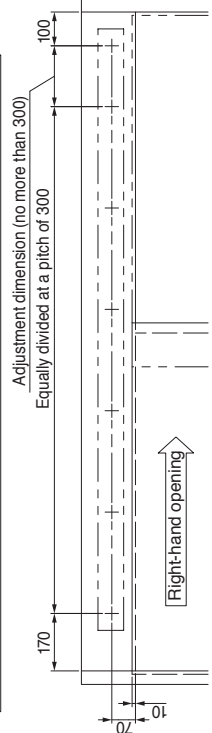


Remarks

1. These diagrams represent a right-hand opening type. The left-hand opening type is a mirror image of these diagrams.
2. Door orientation is right-handed if the door is opened rightwards as viewed from the maintenance panel and left-handed if the door is opened leftwards.



Position diagram for rail-mounting holes (as viewed from inspection panel) M5 (P=0.8)



Remarks

- These diagrams represent a right-hand opening type. The left-hand opening type is a mirror image of these diagrams.
- Door orientation is right-handed if the door is opened rightwards as viewed from the maintenance panel and left-handed if the door is opened leftwards.

Features

- Combining with standard sliding door closers, this option enables two sliding doors telescopic-open and closes both doors automatically.
- Allows to secure wide door opening even where door pocket space is limited.
- The product can be used for both left and right hand sliding doors.

Specification

Base model		Item No,	Applicable door weight	Max. width of effective opening
Series name	Model			
C series	DSC-CW03	SC-2S-G16-W	30 kg or less	800-1500 mm
	DSC-CW08	SC-2S-G16-WP	80 kg or less	
	NSC-CW23	SC-2S-G16-W	30 kg or less	
	NSC-CW48	SC-2S-G16-WP	80 kg or less	
	DSC-C03	SC-2S-G** -ST ^{*1}	30 kg or less	
	DSC-C08		80 kg or less	
NSC-C48				
CV series	DSC-CW30V	SC-2S-CWV-G16	30 kg or less	800-1500 mm
	DSC-CW60V		60 kg or less	
	NSC-CW60V			
	DSC-C30V	SC-2S-CV-G** ^{*1}	30 kg or less	
	DSC-C60V		60 kg or less	
	NSC-C60V			

*1. SC-2S-G** models : "*" represents the diameter of guide roller.
 (Example SC-2S-G25-ST is for Ø25 guide roller.) Selection from Ø16/Ø25/Ø30/Ø35.
 *2. Not applicable to pocket door.
 *3. Following items are required for the single action double sliding (telescopic) system.

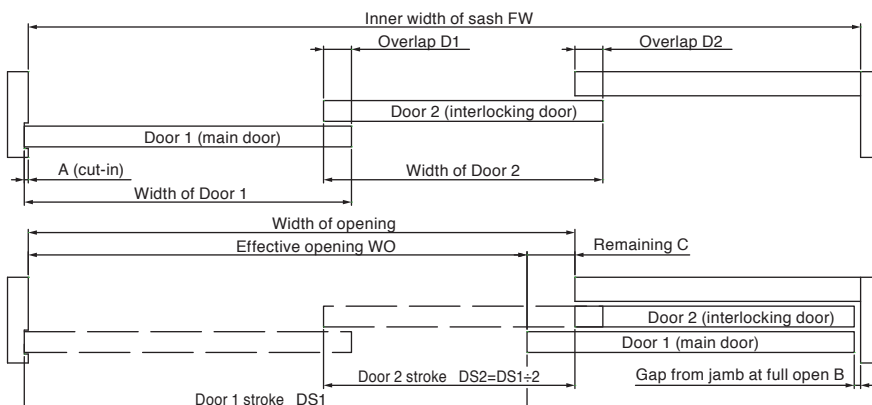


System components	Q'ty	Remark
① Standard set (Base model)	1 set	
② Single action double sliding kit	1 set	Telescopic bracket, hangers for Door 2, door stop for Door 2, mounting plate for wooden door (WP only)
③ Rail for Door 2 (interlocking door)	1 set	
④ Guide rail for Door 2 (interlocking door)	1 set	For CW type base models

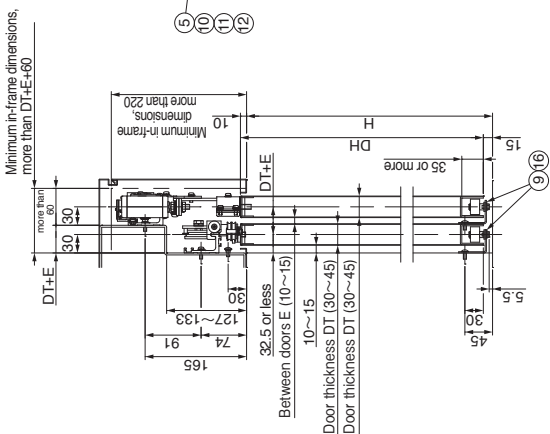
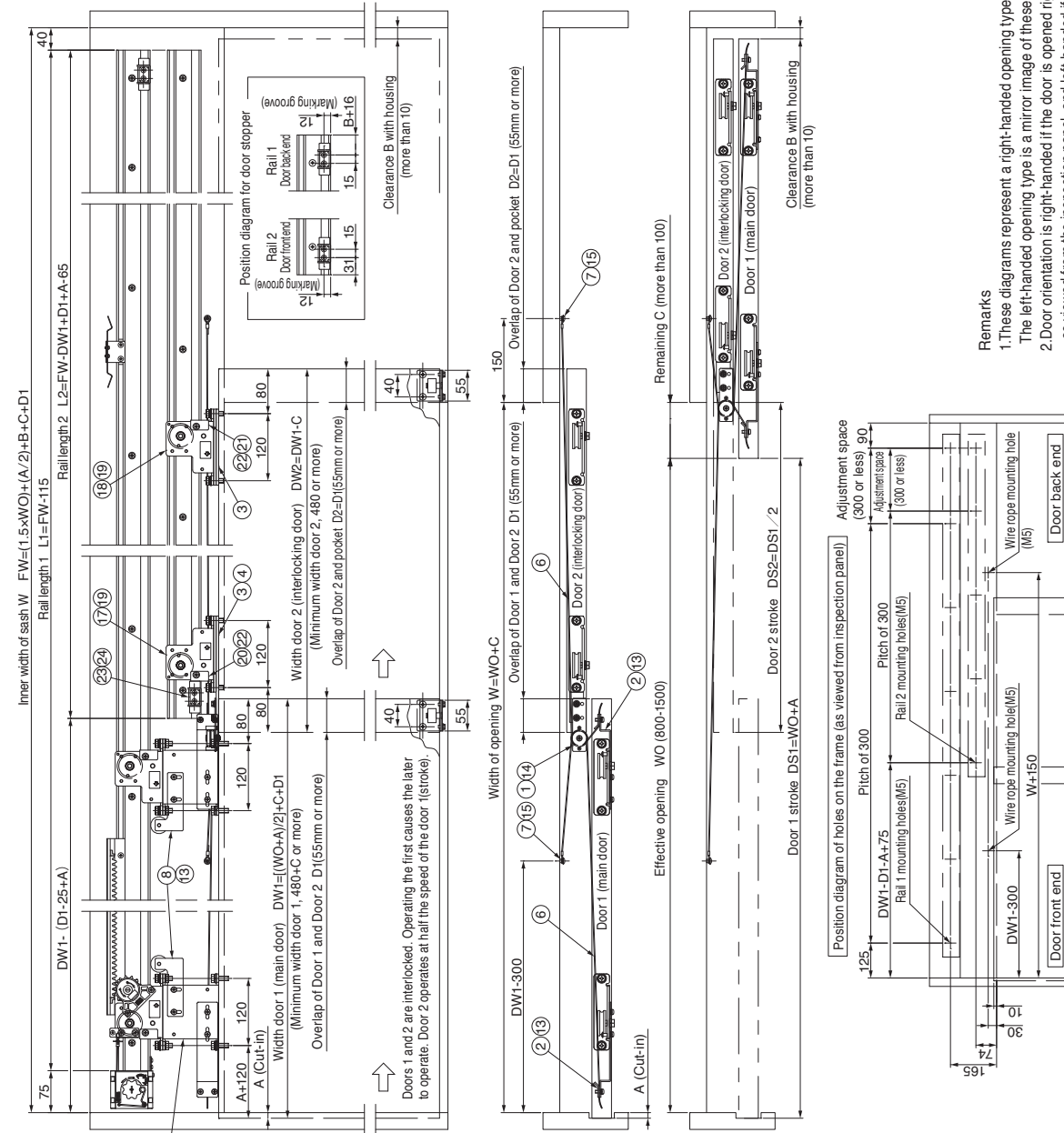
- Order example**
- ① NSC-CW48-311 SET
 - ② SC-2S-G16-WP1 SET
 - ③ Rail L=22001 SET
 - ④ Guide rail L=13001 SET

Calculation formula for main dimensions

Item	Code	Formula	
		Effective opening (reference)	Inner width of sash (reference)
Effective opening(800-1500)	WO	Please specify	$\frac{FW - (A/2) - B + C + D1}{1.5}$
Inner width of sash(3215 or less)	FW	$(1.5 \times WO) + A/2 + B + C + D1$	Please specify
Cut-in (door front end)	A	Please specify	Please specify
Gap from jamb at full open position (10mm or more)	B	Please specify	Please specify
Remaining (100mm or more)	C	Please specify	Please specify
Overlap of Door 1 (main door) and Door 2 (interlocking door) (55mm or more)	D1	Please specify	Please specify
Overlap of Door 2 (interlocking door) and pocket (55mm or more)	D2	$D2 = D1$	$D2 = D1$
Width of door 1 (main door), (580mm or more)	DW1	$\frac{WO + A}{2} + C + D1$ (580 or more)	$\frac{WO + A}{2} + C + D1$
Width of door 2 (interlocking door), (480mm or more)	DW2	$DW1 - C$	$DW1 - C$ (480 or more)
Width of opening	W	$WO + C$	$WO + C$
Rail length for Door 1 (main door)	L1	$FW - 115$	$FW - 115$
Rail length for Door 2 (interlocking door)	L2	$FW - DW1 + D1 + A - 65$	$FW - DW1 + D1 + A - 65$



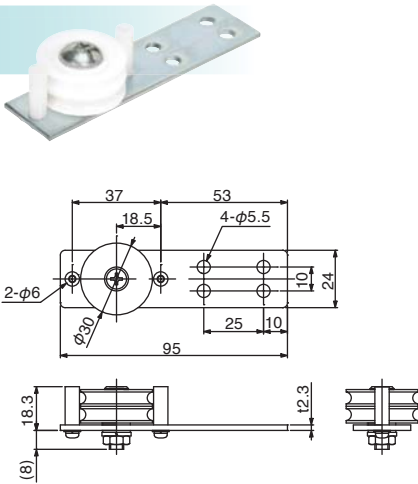
With this single action double sliding kit, the stroke of Door 2 (DS2) always becomes 1/2 of the stroke of Door 1 (DS1). Make sure that your door design complies DS2 = DS1 x 1/2.



Remarks
1. These diagrams represent a right-handed opening type.
The left-handed opening type is a mirror image of these diagrams.
2. Door orientation is right-handed if the door is opened rightwards as viewed from the inspection panel, and left-handed if the door is opened leftwards.

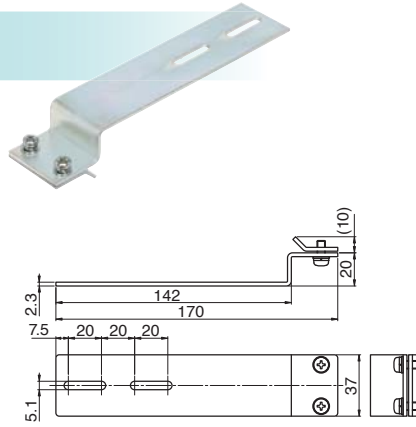
No.	Part	Qty	Remark
①	Pulley fitting	1	
②	Wire fitting	2	
③	Liner S	3	
④	Liner L	1	
⑤	Hanger base	2	
⑥	Wire rope	2	
⑦	Wire fastener on frame	2	
⑧	Rebound-preventive fitting	2	
⑨	Guide roller AJ	2	Ø16, Ø25, Ø35
⑩	M8X25 Hexagon bolt	4	
⑪	M8 Hexagonal nut	4	For installing hanger base and hanger.
⑫	M8 Plain washer	4	
⑬	M5x12 pan head screw	8	Wire fitting, for installing. Rebound-preventive fitting.
⑭	M5x8 cross recessed hexagon head bolt	2	For installing pulley fitting
⑮	M5x12 truss head screw	2	For installing wire fastener on frame
⑯	4.5x20 truss head tapping screw	2	
⑰	M5x12 truss head screw(Stainless steel)	4	For installing guide roller AJ
⑱	5x16 truss head tapping screw(Stainless steel)	4	
⑲	Hanger A	1	For door 2 (interlocking door)
⑲	Hanger B	1	For door 2 (interlocking door)
⑲	8x50 hexagon head bolt	4	
⑲	Door retaining fitting Hanger A	1	
⑲	Door retaining fitting Hanger B	1	For door 2 (interlocking door)
⑲	M5x8 pan head screw	2	
⑲	Door stopper	1	For door 2 (interlocking door)
⑲	5x16 pan head tapping screw	2	

Pulley fitting (Common to SC-2S/SC-2S-CV)



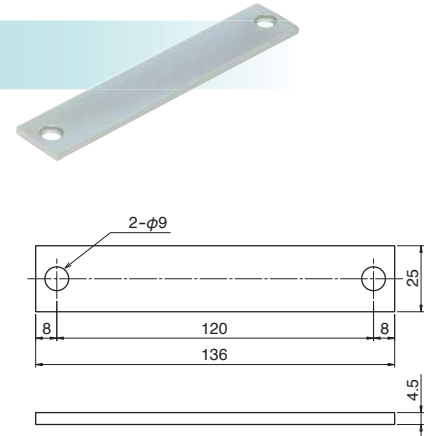
Fitting: Steel
Pulley: Polyacetal

Wire fitting (Common to SC-2S/SC-2S-CV)



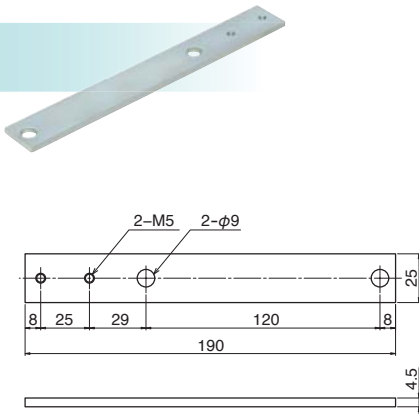
Fitting: Steel

Liner S (Common to SC-2S/SC-2S-CV)



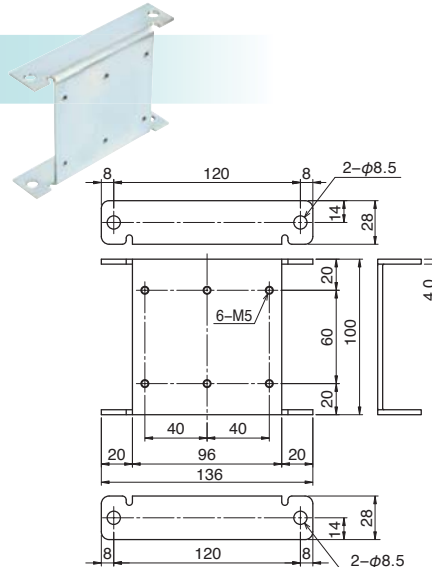
Liner: Steel

Liner L (Common to SC-2S/SC-2S-CV)



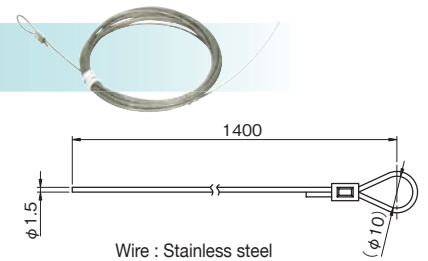
Liner: Steel

Hanger base (Common to SC-2S/SC-2S-CV)



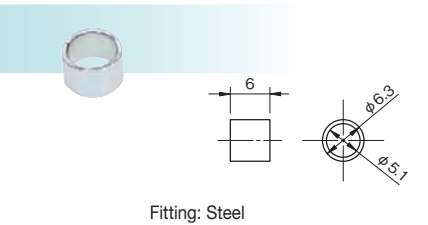
Base: Steel

Wire rope (Common to SC-2S/SC-2S-CV)



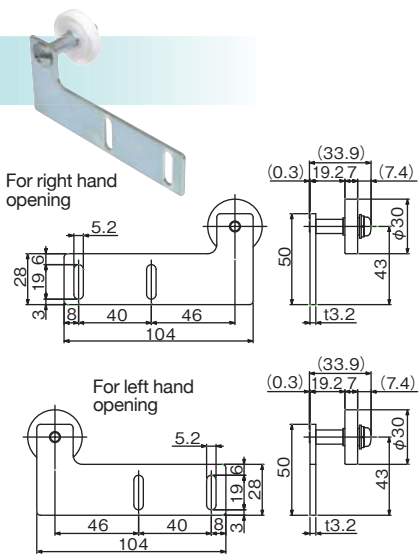
Wire : Stainless steel

Wire fastener on frame
(Common to SC-2S/SC-2S-CV)



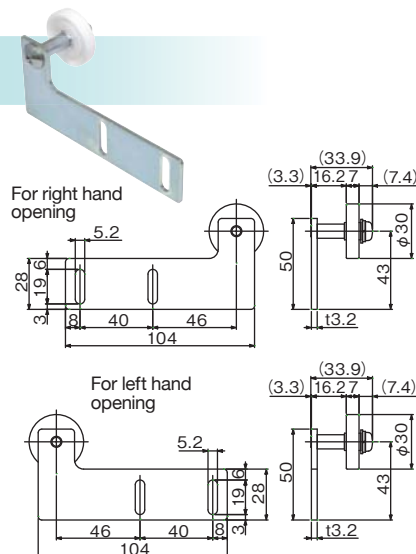
Fitting: Steel

Rebound-preventive fitting (for SC-2S)



Fitting: Steel Pulley: Polyacetal

Rebound-preventive fitting (for SC-2S-CV)



Fitting: Steel Pulley: Polyacetal

Guide roller AJ (Common to SC-2S/SC-2S-CV)

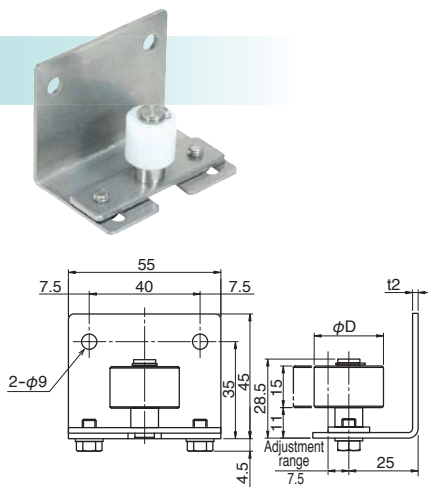


Plate: Stainless steel
Roller: Polyacetal

Option Bi-parting System

Door weight (per one door) : max. 80kg/max. 150kgs/max. 60kg

SC-W type/SC-W-CV type

Features

•Combining with standard sliding door closers, this option enables two bi-parting sliding doors open simultaneously and closes both doors automatically.

•Opening one side of the doors will also open the other door, allowing to secure wide door opening even where space is limited.

Specification

Base model		Item No.	Applicable door weight	Max. width of effective opening
Series name	Model			
C series	DSC-CW03	SC-W	30 kg or less	Up to 3000 mm
	DSC-CW08		80 kg or less	
	NSC-CW23		30 kg or less	
	NSC-CW48		80 kg or less	
	DSC-C03		30 kg or less	
	DSC-C08		80 kg or less	
	NSC-C48		150 kg or less	
	DSC-C015		150 kg or less	
CV series	DSC-CW30V	SC-W-CV	30 kg or less	Up to 3000 mm
	DSC-CW60V		60 kg or less	
	NSC-CW60V		30 kg or less	
	DSC-C30V		30 kg or less	
	DSC-C60V		60 kg or less	
	NSC-C60V		60 kg or less	

*1. Not applicable to pocket door.

*2. Following items are required for the bi-parting system.

System components	Q'ty	Remark
① Standard set (Base model)	2 set	
② Bi-parting System kit	1 set	
③ Door stopper	2 set	Central door stopper



Order example

- ① NSC-C48-22 2 SET
- ② Bi-parting System kit 1 SET
- ③ Door stopper 2 SET

SC-W/SC-W-CV Bi-parting System

Dimension diagram

<p>Adjustment fitting L (Common to SC-W / SC-W-CV)</p>	<p>Adjustment fitting R (Common to SC-W / SC-W-CV)</p>	<p>Wire rope (Common to SC-W / SC-W-CV)</p> <p>Wire: Stainless steel</p>
<p>Angle L (Common to SC-W / SC-W-CV)</p> <p>Angle: Steel</p>	<p>Angle R (Common to SC-W / SC-W-CV)</p> <p>Angle: Steel</p>	<p>Aluminum sleeve (Common to SC-W / SC-W-CV)</p> <p>Aluminum sleeve: Aluminum</p>
		<p>Door stopper (For C Series)</p> <p>Bracket: Stainless Rubber door stopper: Synthetic rubber</p>
		<p>Door stopper (For CV Series)</p> <p>Bracket: Steel Rubber door stopper: Synthetic rubber</p>

Features

- This option allows the door to stop and hold at any desired position.
- To release the hold, lightly pull the door to closing direction so the door will automatically close.

- This option can be added on to the existing sliding door closer.
- The product can be used for both left and right hand sliding doors.

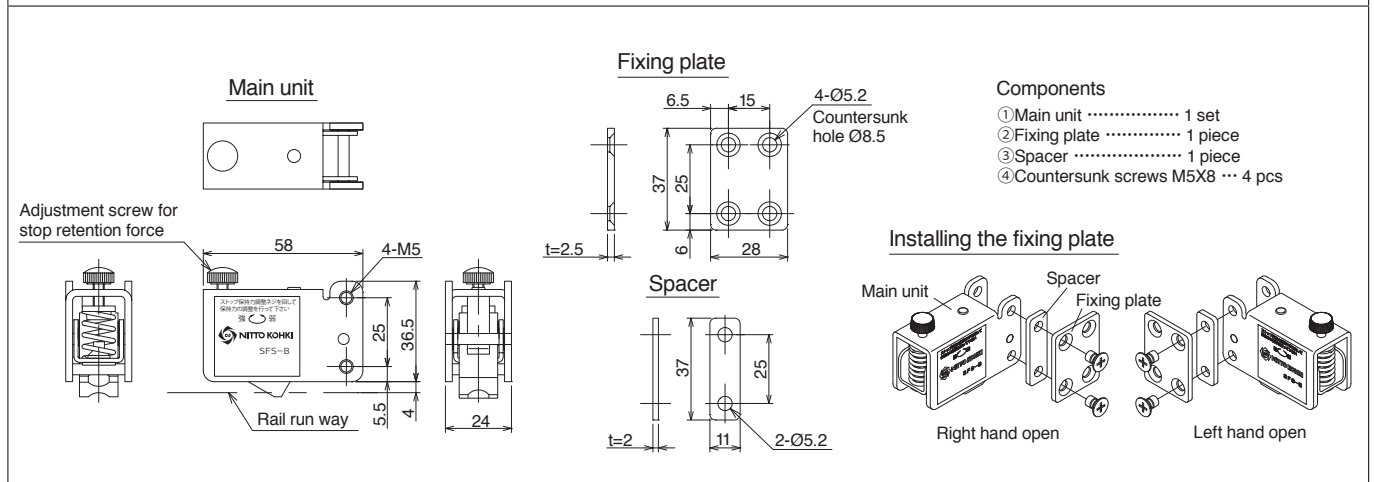
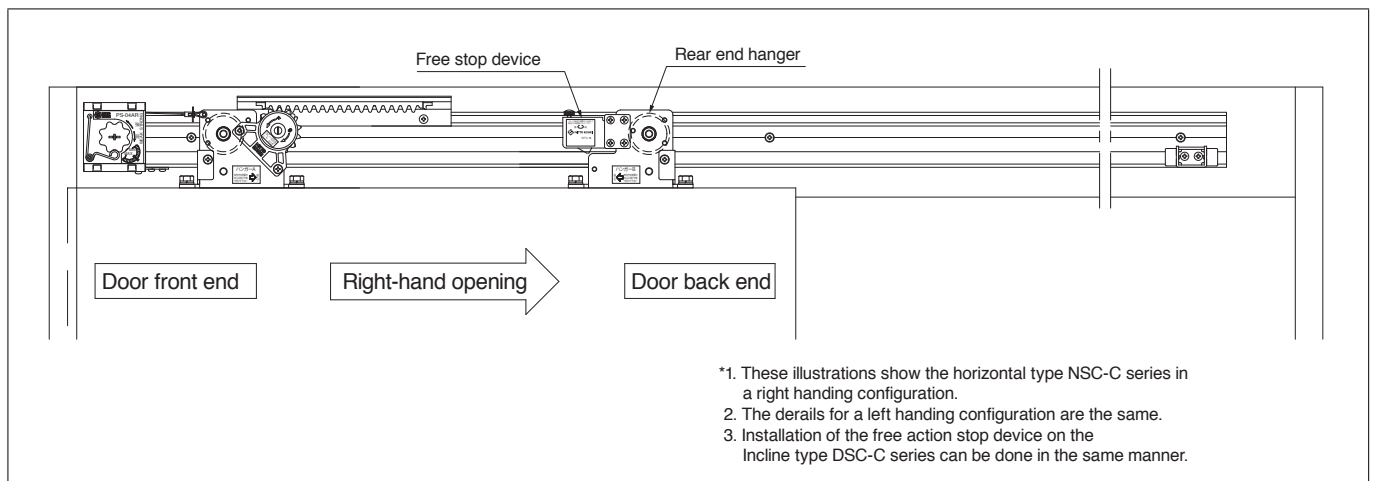
Specification

Series	Base model		Free stop device Model
	Incline	Horizontal	
C series	DSC-CW03	NSC-CW23	SFS-B type
	DSC-CW08	NSC-CW48	
	DSC-CWKS03	NSC-CWKS23	
	DSC-CWKS08	NSC-CWKS48	
	DSC-C03	NSC-C48	
	DSC-C08	NSC-CKS48	
	DSC-CKS03	NSC-CA48	
	DSC-CKS08		
	DSC-C015	NSC-C1215	SFS-B-H type
CV series	DSC-CW30V	NSC-CW60V	SFS-B-CV type
	DSC-CW60V	NSC-CWKS60V	
	DSC-CWKS30V	NSC-C60V	
	DSC-CWKS60V	NSC-CKS60V	
	DSC-C30V		
	DSC-C60V		
	DSC-CKS30V		
	DSC-CKS60V		



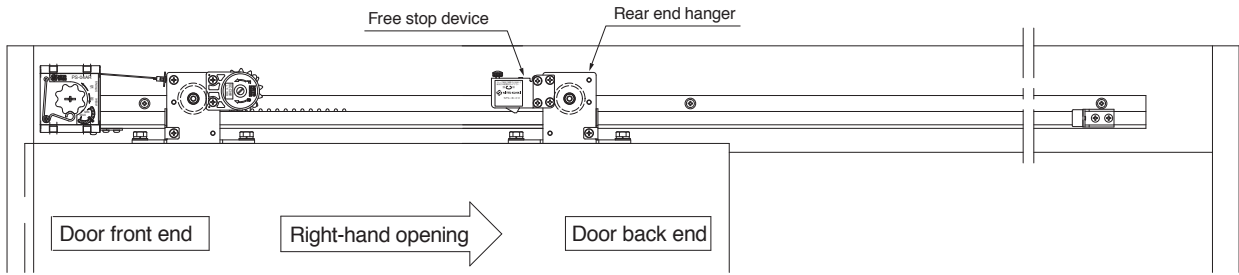
Free stop device SFS-B type

Dimension diagram

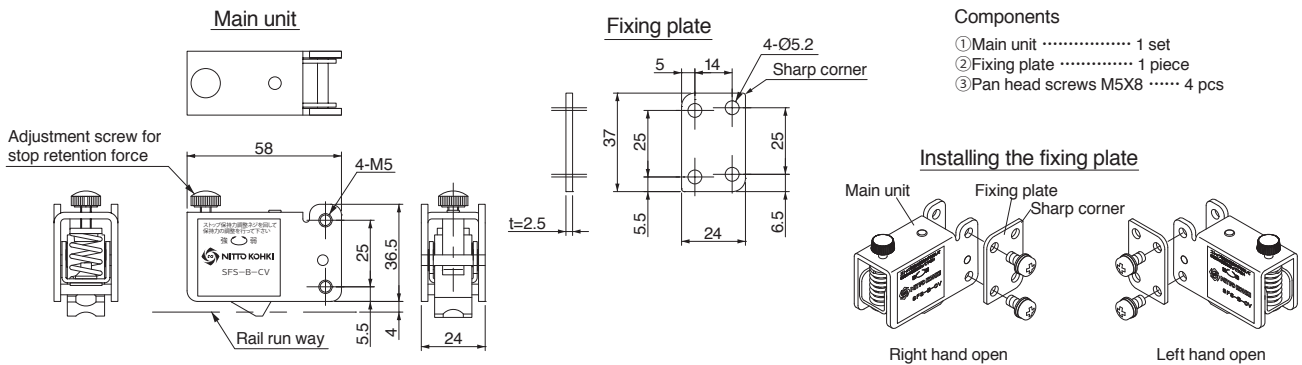


Free stop device SFS-B-CV type

Dimension diagram

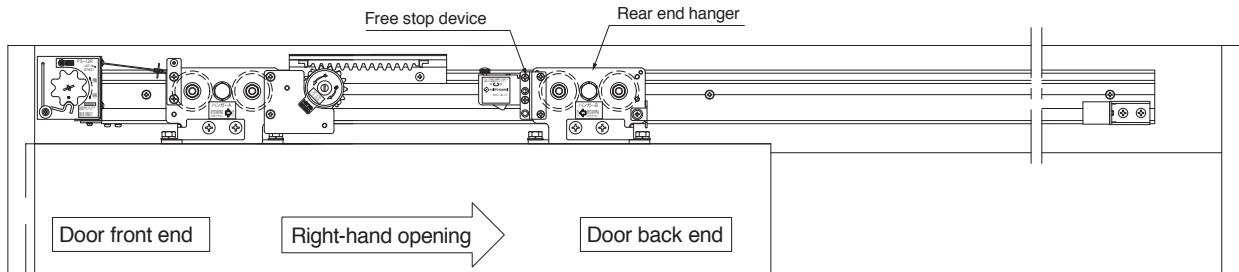


- *1. These illustrations show the horizontal type NSC-CV series in a right handing configuration.
2. The details for a left handing configuration are the same.
3. Installation of the free action stop device on the Incline type DSC-CV series can be done in the same manner.

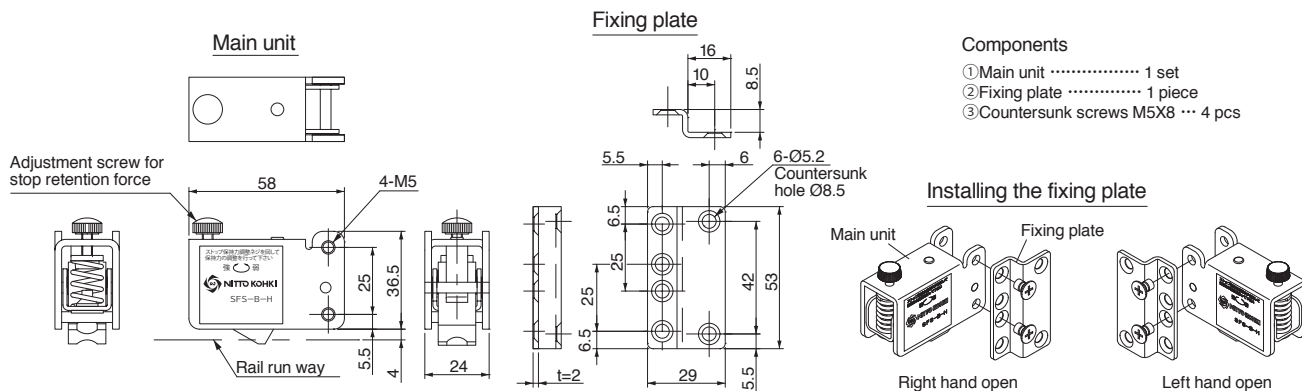


Free stop device SFS-B-H type

Dimension diagram

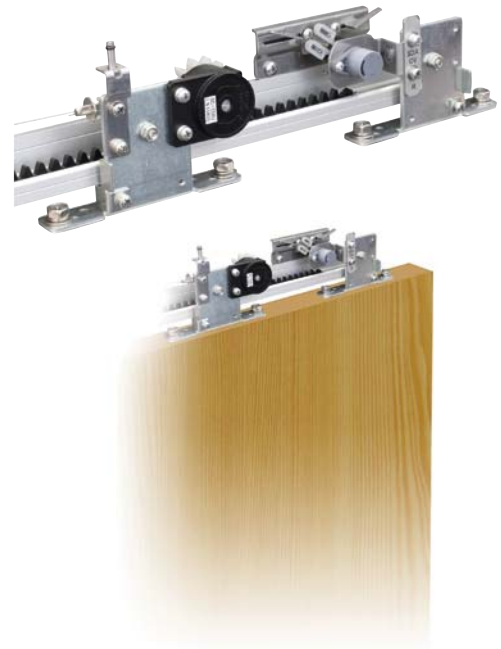


- *1. These illustrations show the horizontal type NSC-C1215 in a right handing configuration.
2. The details for a left handing configuration are the same.
3. Installation of the free action stop device on the Incline type DSC-C015 can be done in the same manner.



Features

- This option holds the door at full open position and automatically releases it after desired time period (settable between 0-15sec).
- Increases safety during the passage for all, including the elderly, small children, people of limited mobility and those who carries cargo.



Specification

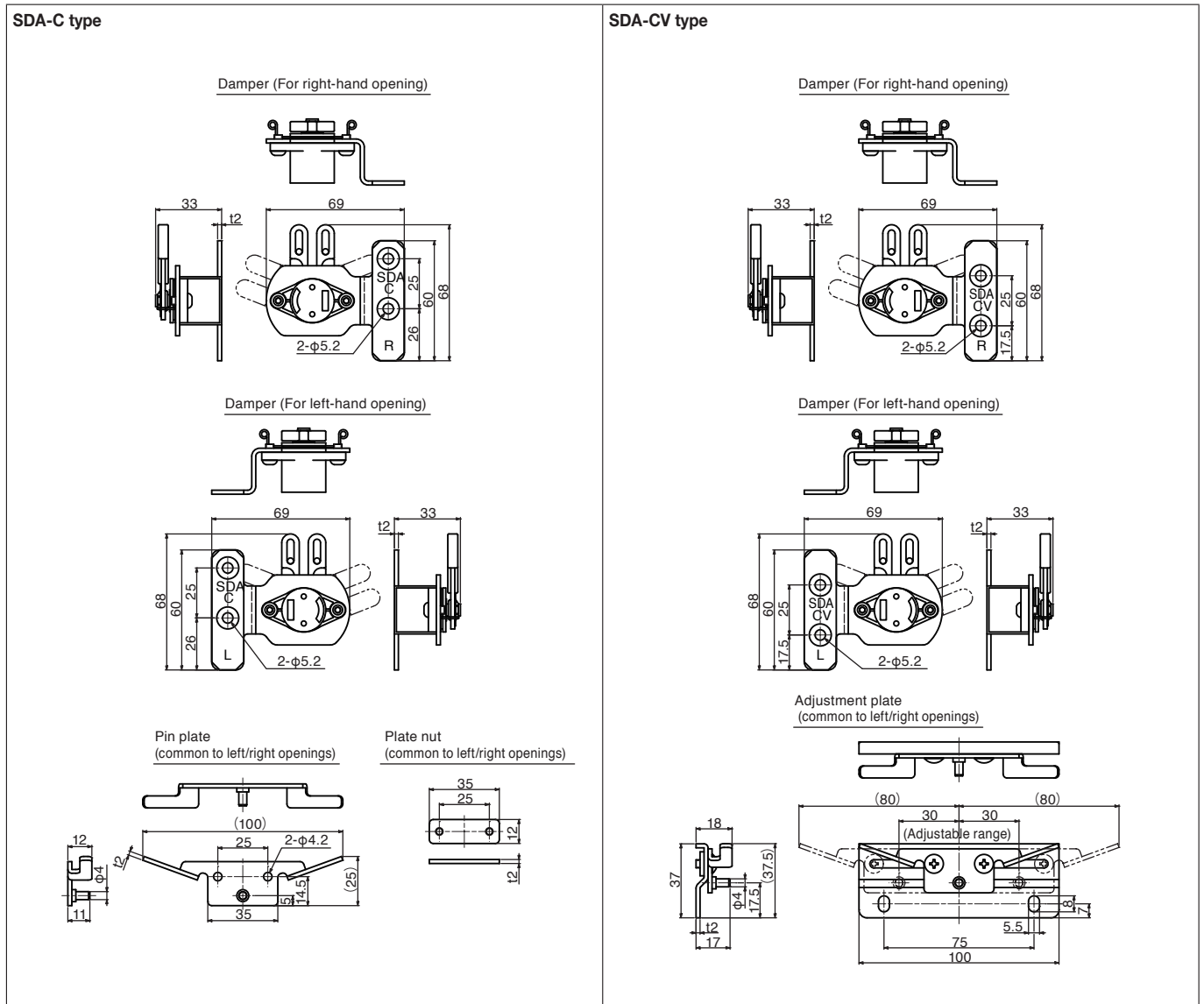
Series	Base model		Delayed device Model
	Incline	Horizontal	
C series	DSC-CW03	NSC-CW23	For right-handed opening: SDA-C-R type
	DSC-CW08	NSC-CW48	
	DSC-C03	NSC-C48	For left-handed opening: SDA-C-L type
	DSC-C08	NSC-CA48	
CV series	DSC-CW30V	NSC-CW60V	For right-handed opening: SDA-CV-R type
	DSC-CW60V	NSC-C60V	
	DSC-C30V		For left-handed opening: SDA-CV-L type
	DSC-C60V		

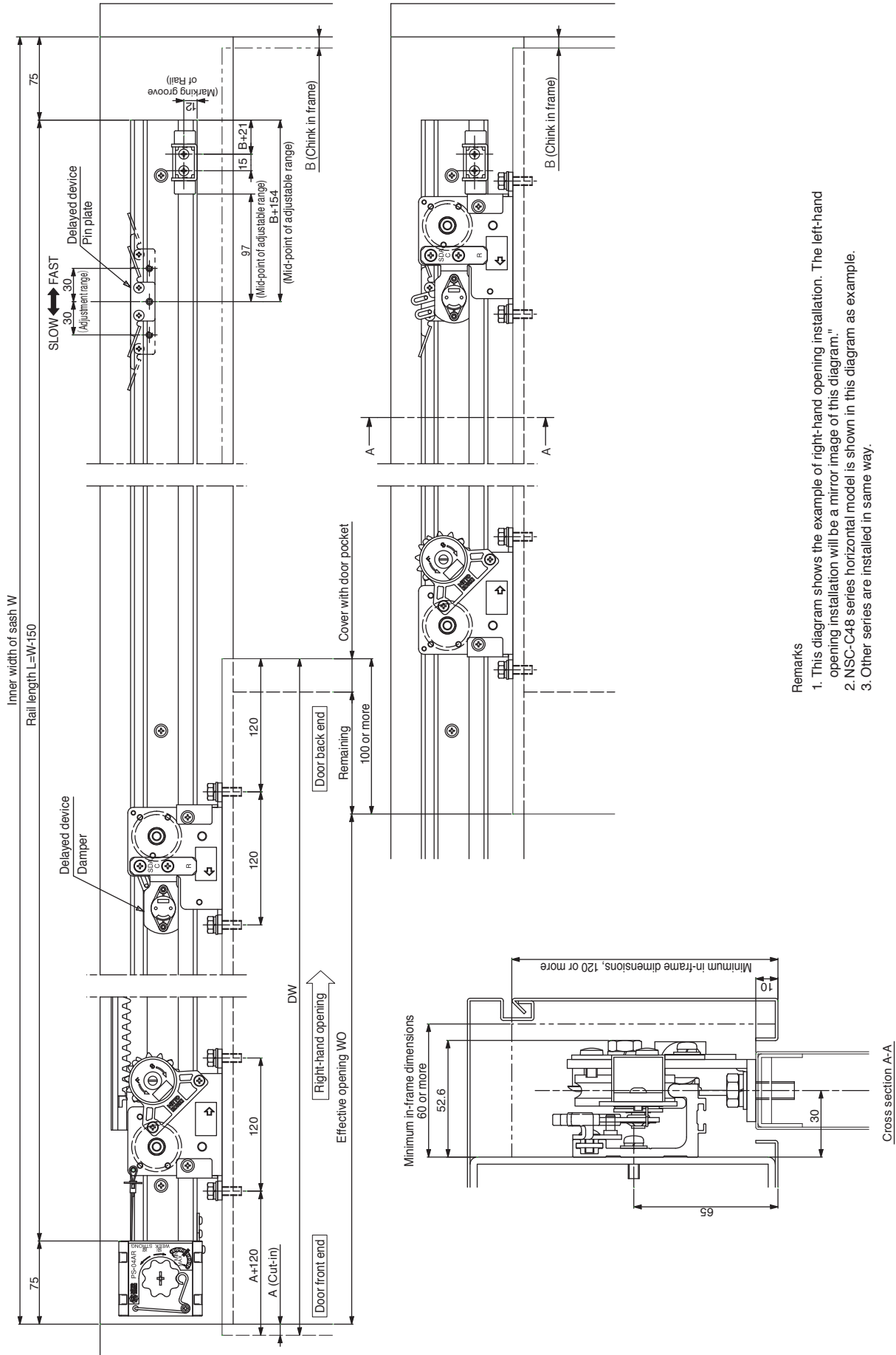
*1 Not applicable to pocket door.

*2 This product is handed. Choose left-hand or right-hand opening type when ordering.

Delayed device

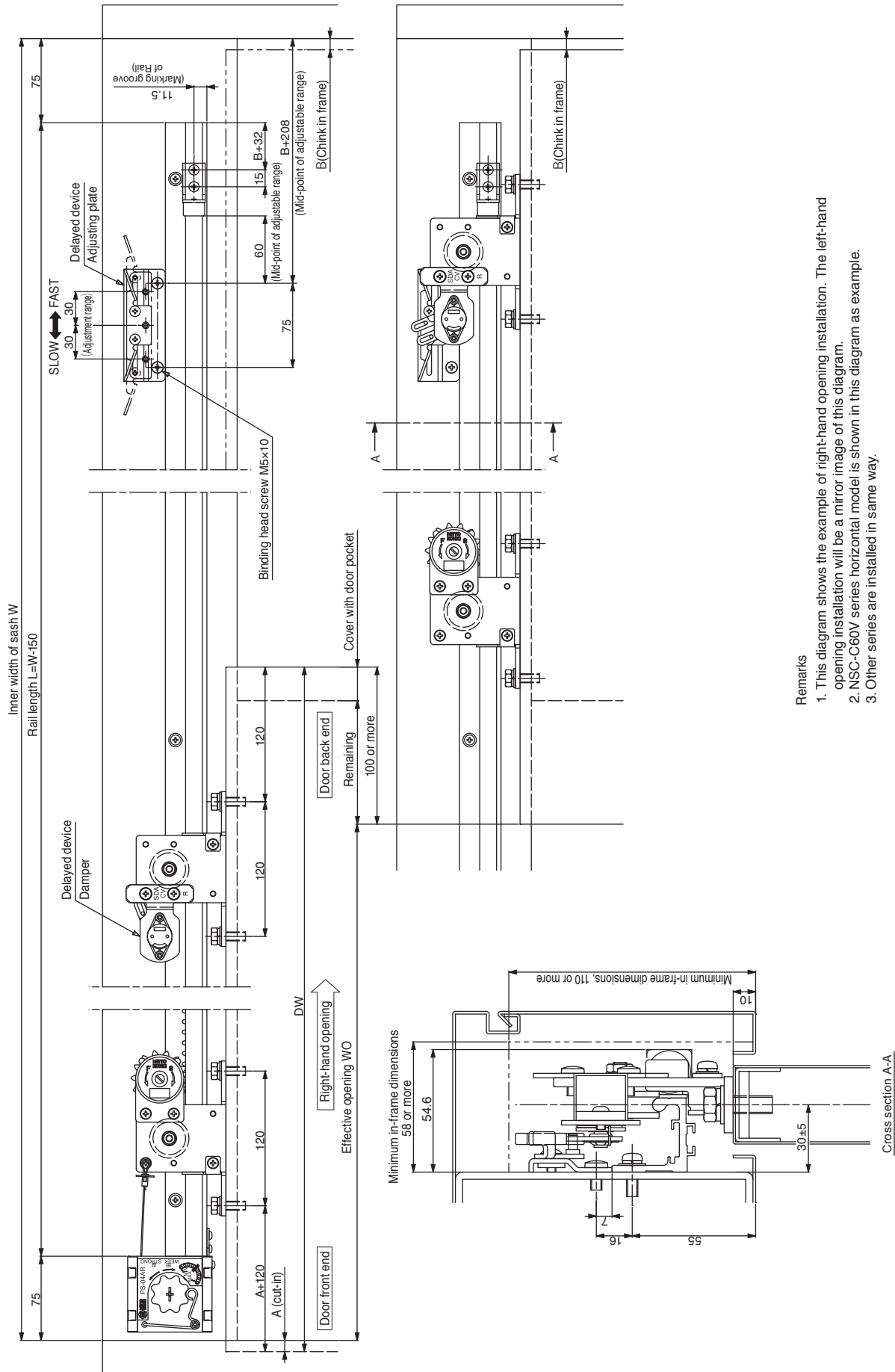
Dimension diagram





Remarks

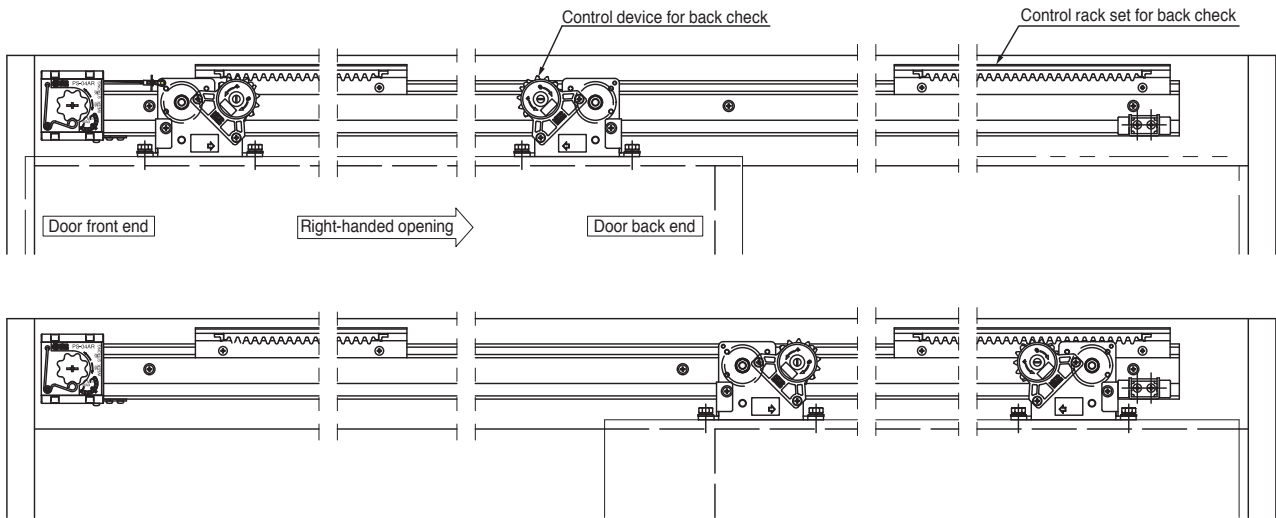
1. This diagram shows the example of right-hand opening installation. The left-hand opening installation will be a mirror image of this diagram."
2. NSC-C48 series horizontal model is shown in this diagram as example.
3. Other series are installed in same way.



Remarks

1. This diagram shows the example of right-hand opening installation. The left-hand opening installation will be a mirror image of this diagram.
2. NSC-C60V series horizontal model is shown in this diagram as example.
3. Other series are installed in same way.

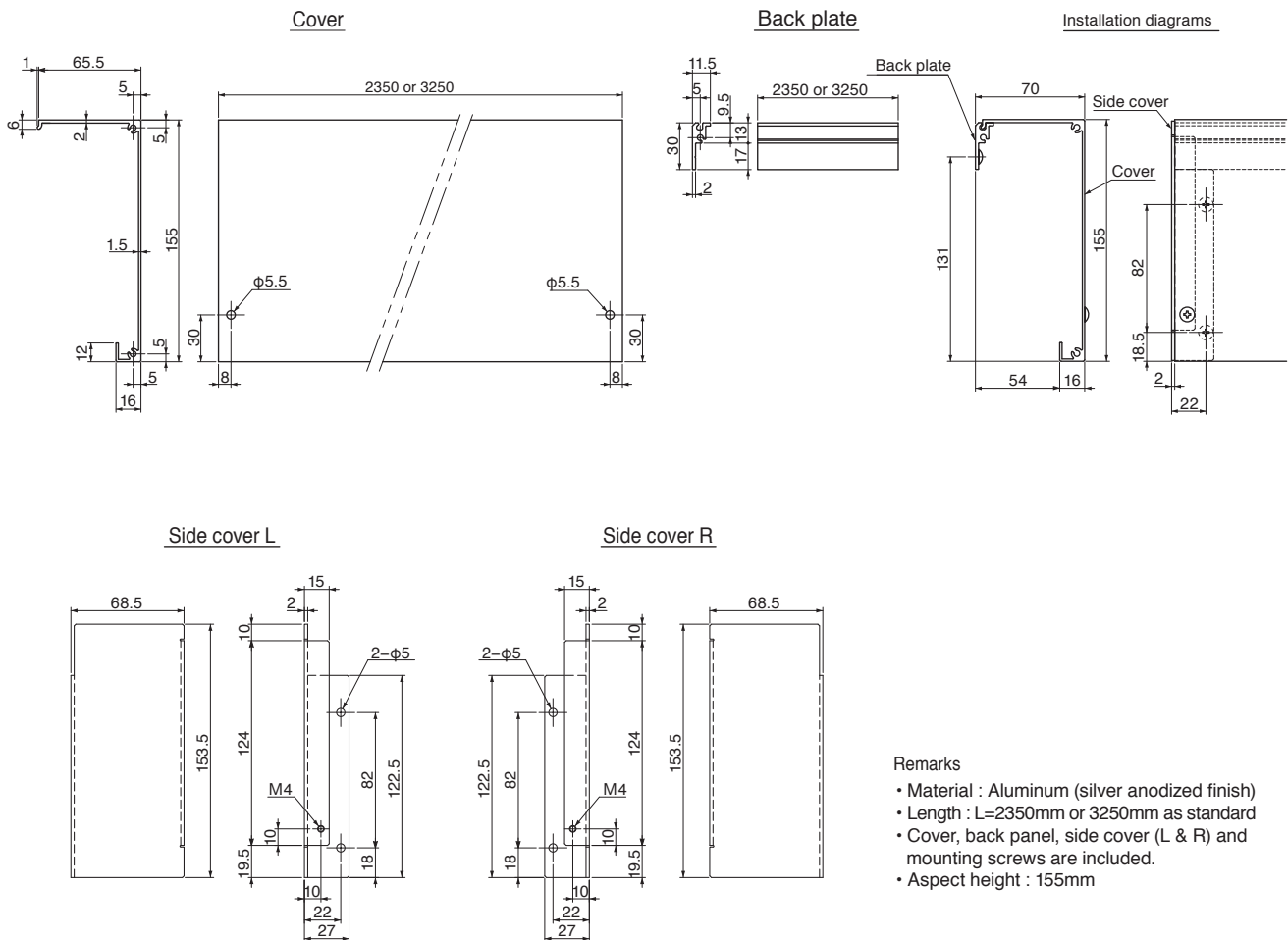
Back check device installation diagrams



Remarks

1. This diagram shows the example of right-hand opening installation.
The left-hand opening installation will be a mirror image of this diagram.
2. NSC-C48 series horizontal model is shown in this diagram as example.
3. By installing additional control device and control rack at the door back end, the damper works towards the door opening direction.
(*The clutch gear of the control device for back check device must be installed in reverse.)
4. Other series are installed in same way.

Dimension diagram for maintenance panel

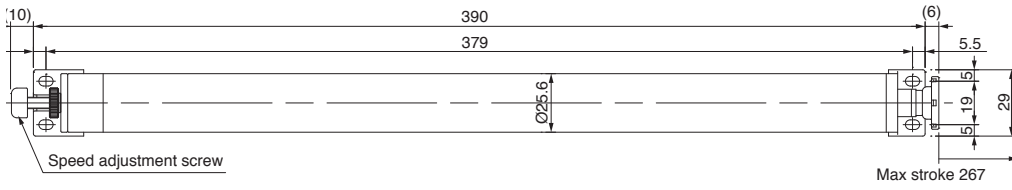


Remarks

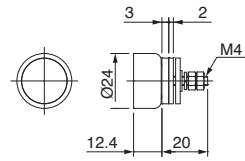
- Material : Aluminum (silver anodized finish)
- Length : L=2350mm or 3250mm as standard
- Cover, back panel, side cover (L & R) and mounting screws are included.
- Aspect height : 155mm

Air damper unit

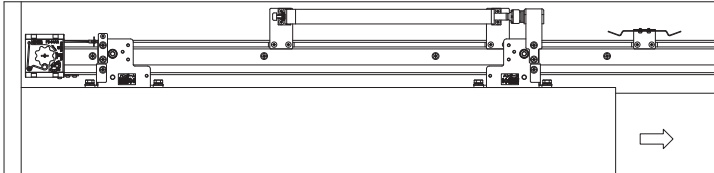
Air damper (Common)



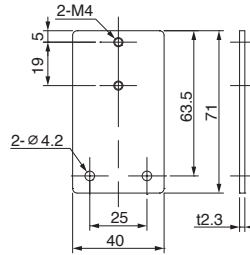
Magnet (Common)



SCA-C



Mounting bracket for air damper



Mounting bracket for magnet

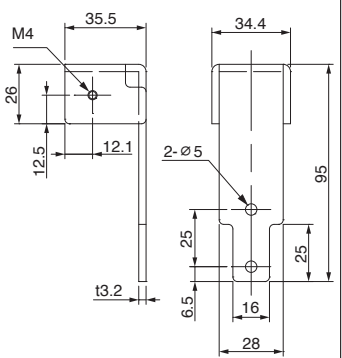
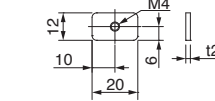


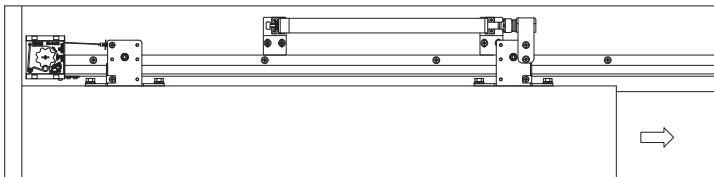
Plate nut



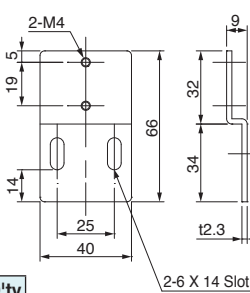
Applicable Models Parts list

Model	Parts name	Q'ty
NSC-CV series	Air damper (Common)	1
DSC-CV series	Magnet (Common)	1
NSC-CKS series	Mounting bracket for air damper	2
DSC-CKS series	Plate nut	4
	Mounting bracket for magnet	1
	M4 × 8 truss head screw	8
	M5 × 10 pan head screw	2

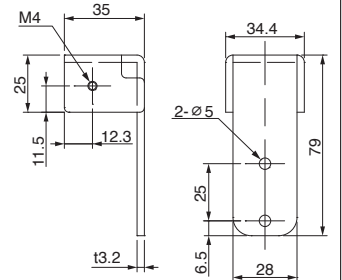
SCA-CV



Mounting bracket for air damper



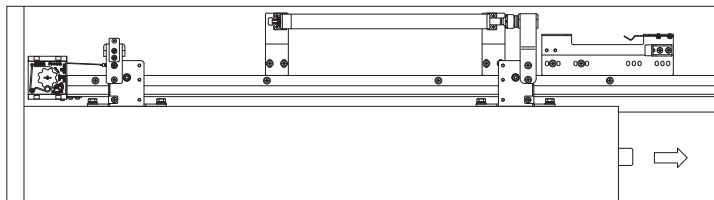
Mounting bracket for magnet



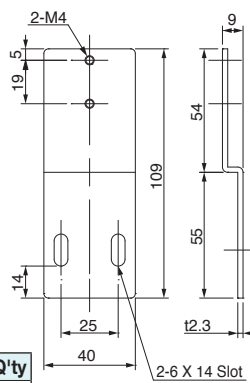
Applicable Models Parts list

Model	Parts name	Q'ty	Parts name	Q'ty
NSC-CV series	Air damper (Common)	1	M4×8 truss head screw	4
DSC-CV series	Magnet (Common)	1	M5×10 pan head screw	4
	Mounting bracket for air damper	2	M5×30 truss head tapping screw	4
	Mounting bracket for magnet	1	M5×10 pan head screw	2

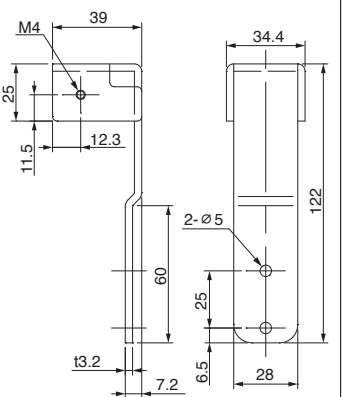
SCA-CKSV



Mounting bracket for air damper



Mounting bracket for magnet



Applicable Models Parts list

Model	Parts name	Q'ty	Parts name	Q'ty
NSC-CKS series	Air damper (Common)	1	M4×8 truss head screw	4
DSC-CKS series	Magnet (Common)	1	M5×10 pan head screw	4
	Mounting bracket for air damper	2	M5×30 truss head tapping screw	4
	Mounting bracket for magnet	1	M5×10 pan head screw	2

Features

- The product catches the door at 25mm from the full close position and firmly latches.
- Useful in the situations where the door is equipped with electronic lock having tight latch or the door gets often bounced back by airtight seal at closure.
- The latching force is adjustable during the installation. (Adjustment range: 5-10N)
- The product can be used for both left and right hand sliding doors.

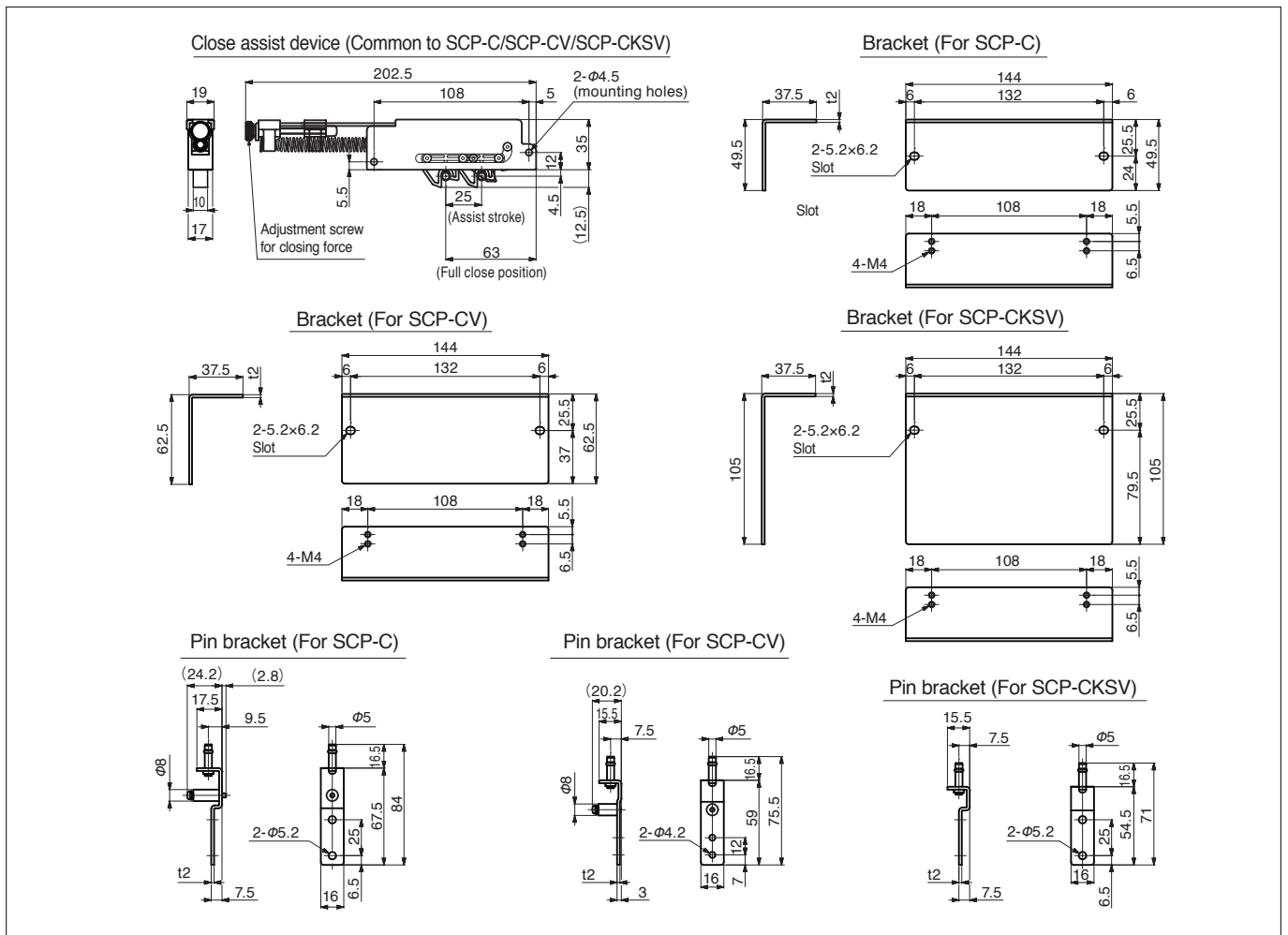
Specification

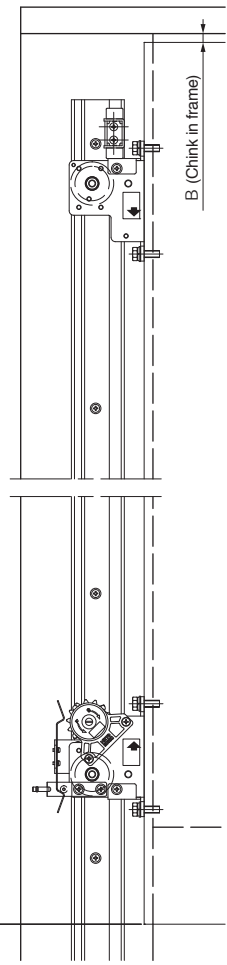
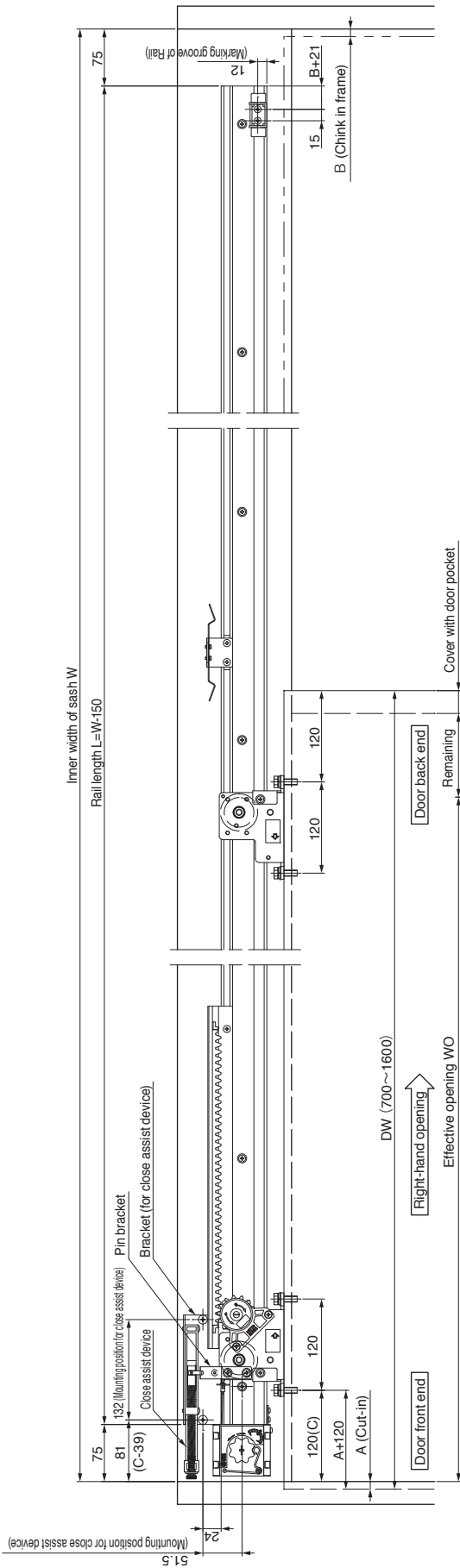
Base model			Close assist device Model
Series	Incline	Horizontal	
C series	DSC-CW03	NSC-CW23	SCP-C type
	DSC-CW08	NSC-CW48	
	DSC-CWKS03	NSC-CWKS23	
	DSC-CWKS08	NSC-CWKS48	
	DSC-C03	NSC-C48	
	DSC-C08	NSC-CKS48	
	DSC-CKS03	NSC-CA48	
	DSC-CKS08		
CV series	DSC-CW30V	NSC-CW60V	SCP-CV type
	DSC-CW60V	NSC-C60V	
	DSC-C30V		
	DSC-C60V		
	DSC-CWKS30V	NSC-CWKS60V	SCP-CKSV type
	DSC-CWKS60V	NSC-CKS60V	
	DSC-CKS30V		
	DSC-CKS60V		



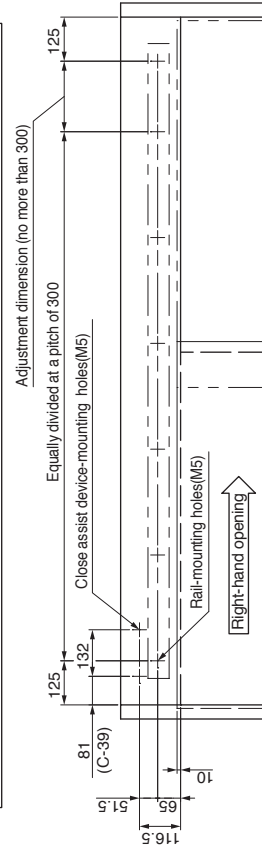
Close assist device (Common to SCP-C/SCP-CV/SCP-CKSV)

Dimension diagram



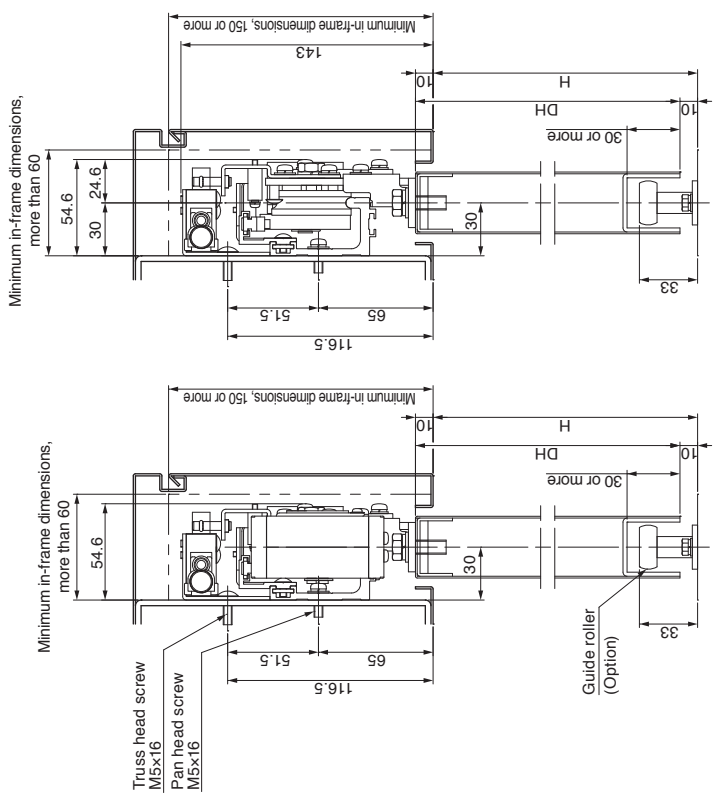


Position diagram for Close assist device and rail mounting holes (as viewed from inspection panel) M5 (P=0.8)

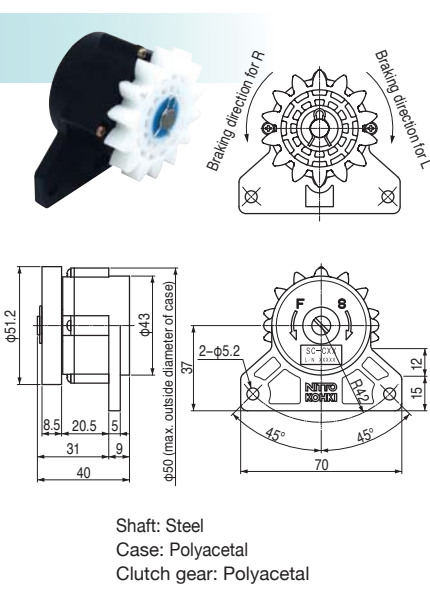


Remarks

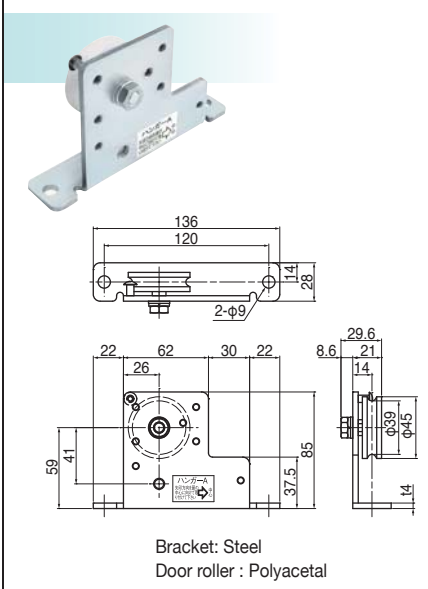
1. This diagram shows the example of right-hand opening installation. The left-hand opening installation will be a mirror image of this diagram.
2. NSC-C48 series horizontal model is shown in this diagram as example.
3. Other series are installed in same way.



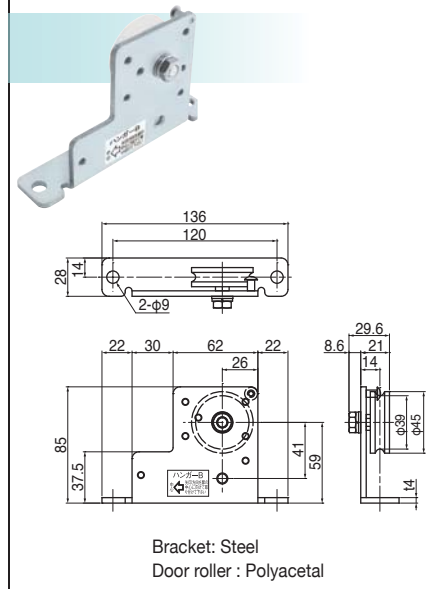
Control device (SC-C03/SC-C08)



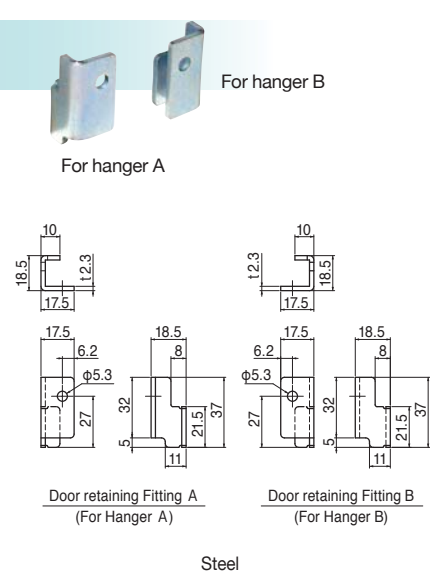
Hanger A



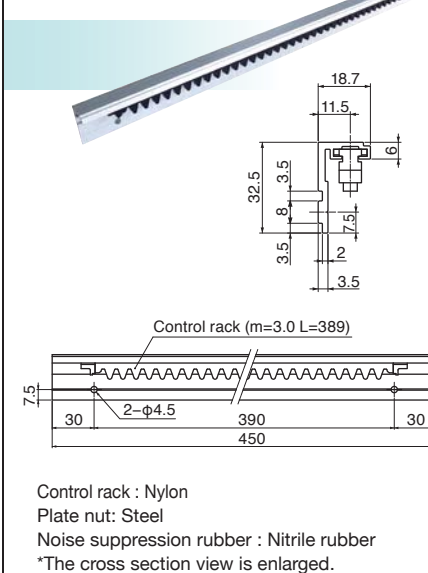
Hanger B



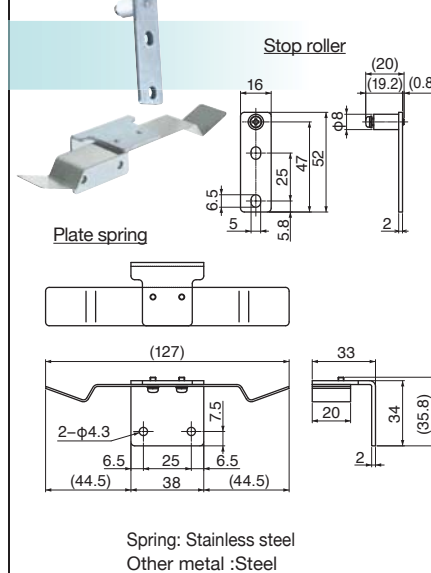
Door retaining fitting Hanger



Control rack set

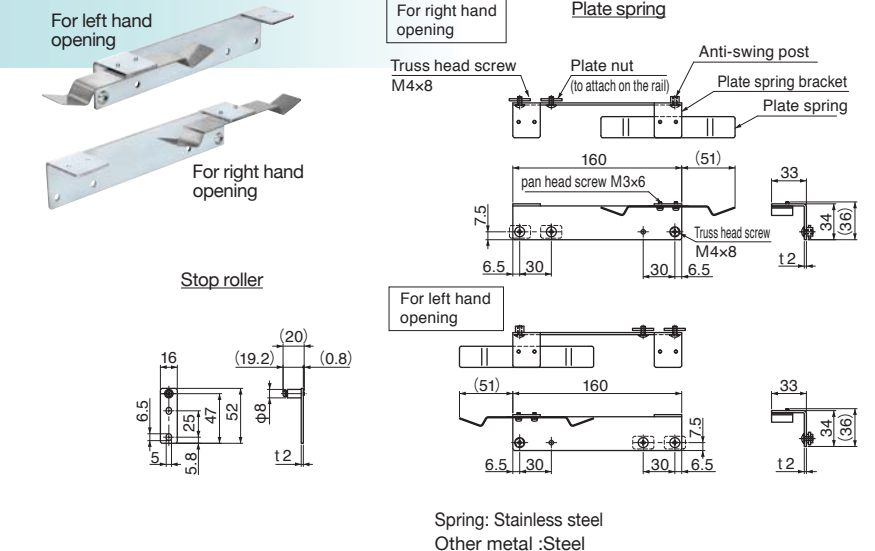


Stop device (for C/CW series)

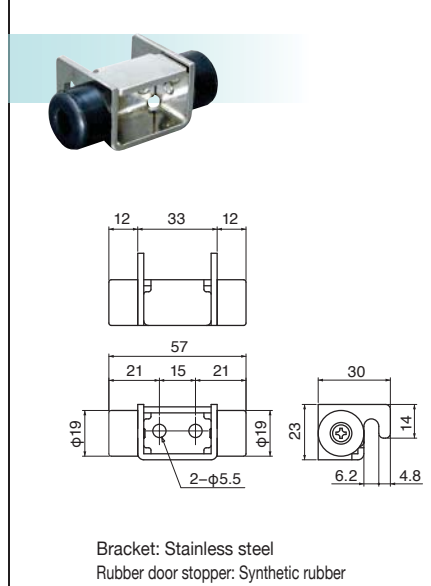


Stop device (for CKS/CWKS series)

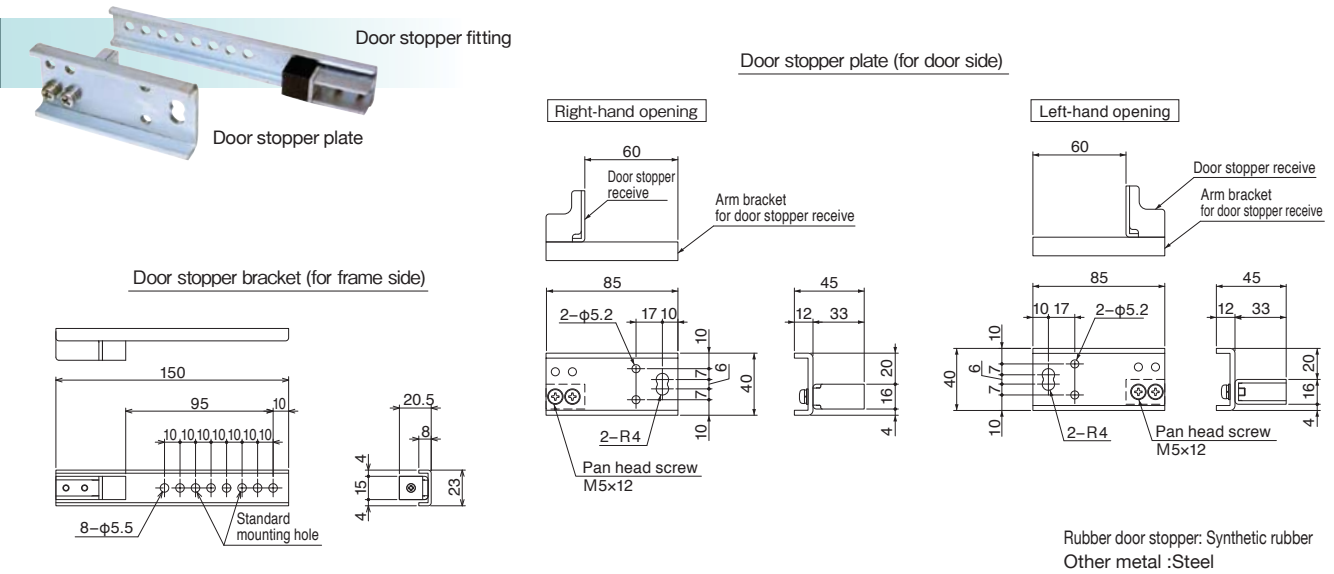
Wall storage type



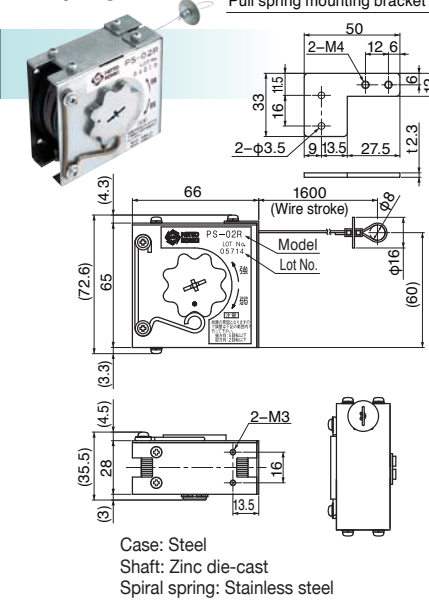
Door stopper (for C/CW series)



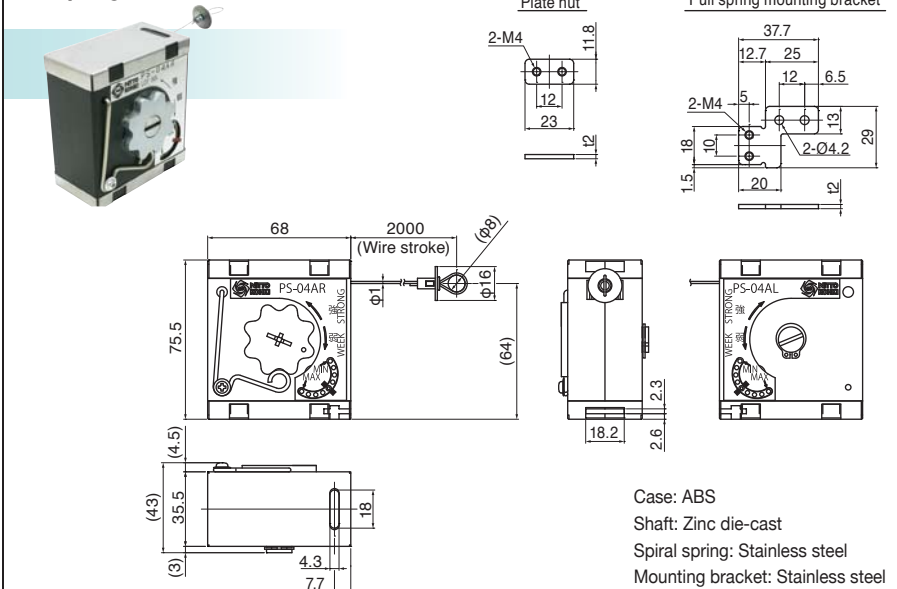
Door stopper (for CKS/CK CWKS series)



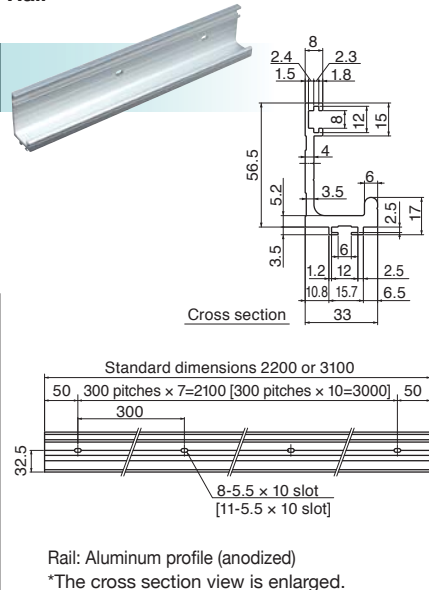
Pull spring (PS-02)



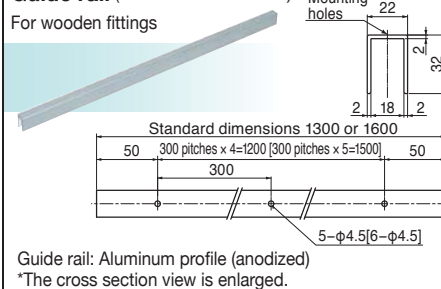
Pull spring (PS-04A)



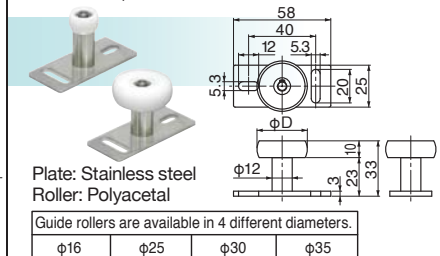
Rail



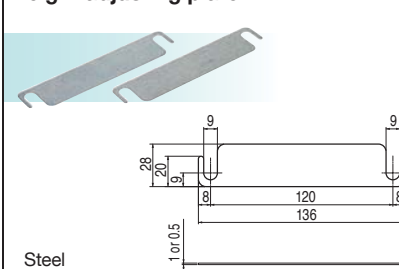
Guide rail (for CW/CWKS series)



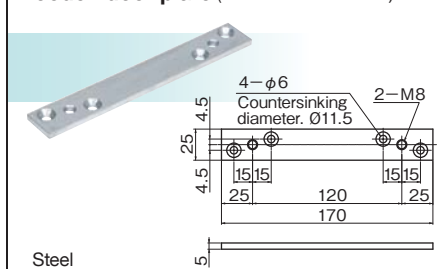
Guide roller (ϕ 16 guide roller is included in CW/CWKS series as standard.)
 Guide roller is option for C/CKS series.



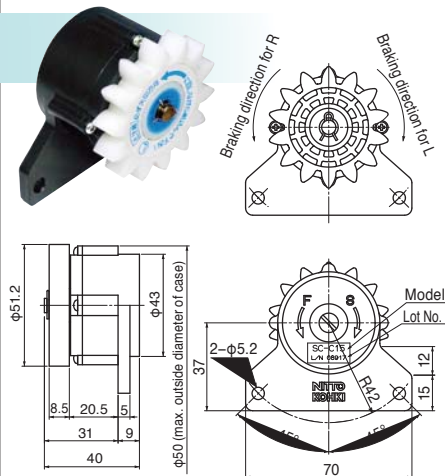
Height adjusting plate



Wooden door plate (for CW/CWKS series)

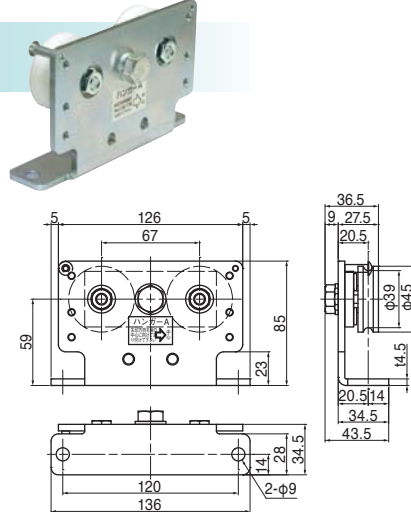


Control device (SC-C15)



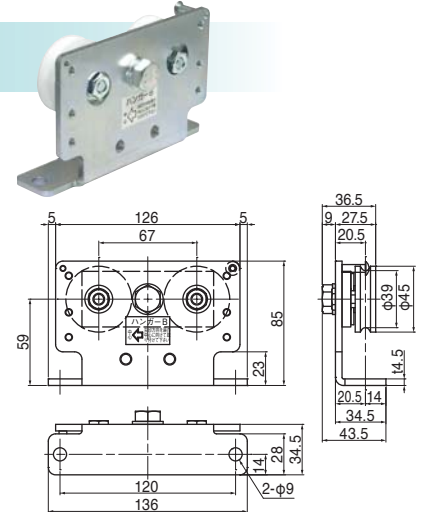
Shaft: Steel
Case: die-cast
Clutch gear: Polyacetal

Hanger A (for 150kg)



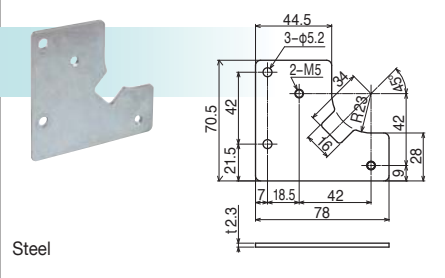
Bracket: Steel
Door roller : Polyacetal

Hanger B (for 150kg)



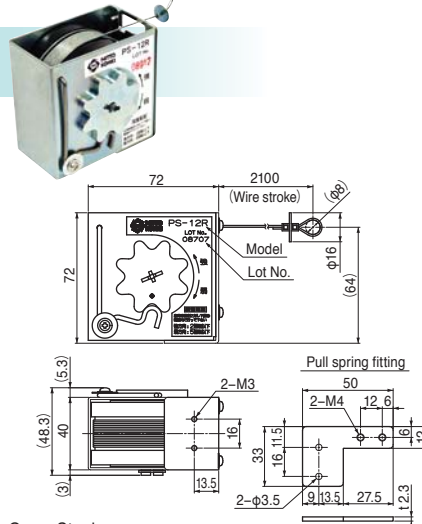
Bracket: Steel
Door roller : Polyacetal

Control device bracket (for 150kg)



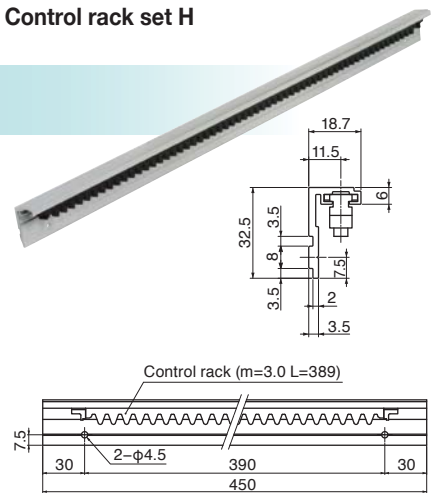
Steel

Pull spring (PS-12)



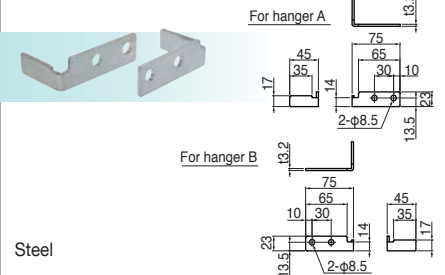
Case: Steel
Shaft: Die-cast
Spiral spring: Stainless steel

Control rack set H



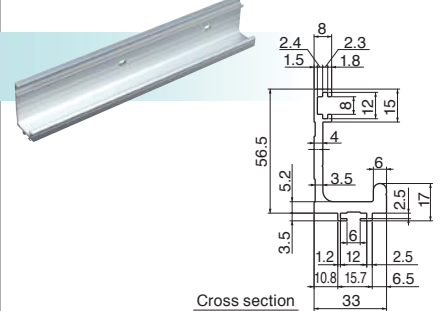
Control rack : Nylon
Plate nut : Steel
*The cross section view is enlarged.

Door retaining fitting Hanger (for 150kg)



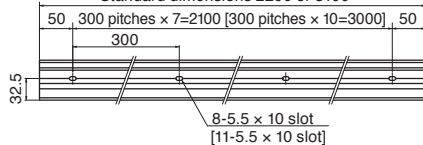
Steel

Rail



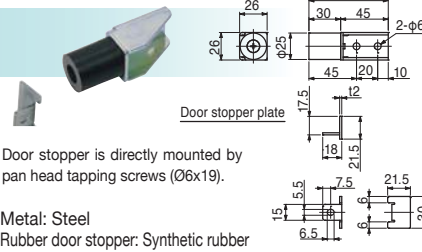
Cross section

Standard dimensions 2200 or 3100



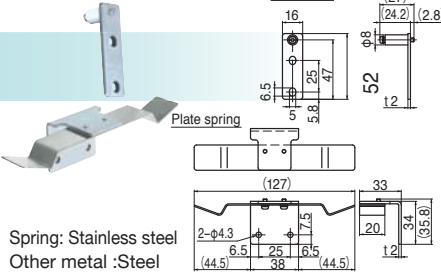
Rail: Aluminum profile (anodized)
*The cross section view is enlarged.

Door stopper (for heavy doors)



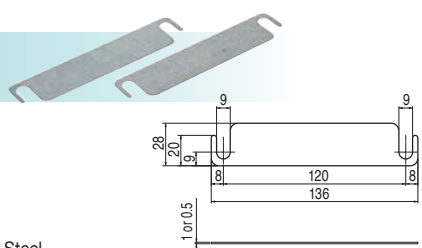
Door stopper is directly mounted by pan head tapping screws (Ø6x19).
Metal: Steel
Rubber door stopper: Synthetic rubber

Stop device (for 150kg)



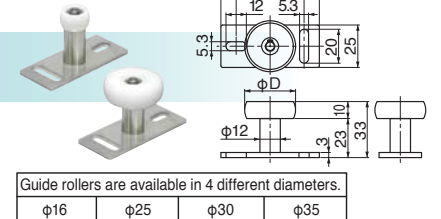
Spring: Stainless steel
Other metal :Steel

Height adjusting plate



Steel

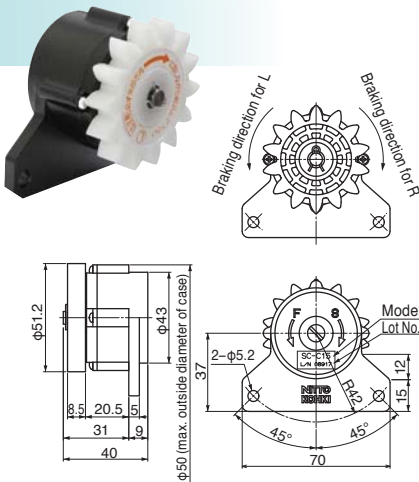
Guide roller



Guide rollers are available in 4 different diameters.
φ16 φ25 φ30 φ35

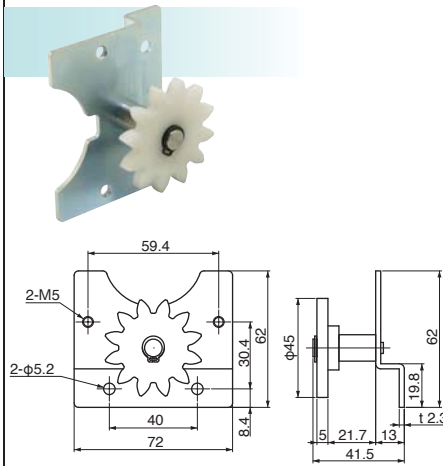
Plate: Stainless steel
Roller: Polyacetal

Control device (SC-C25)



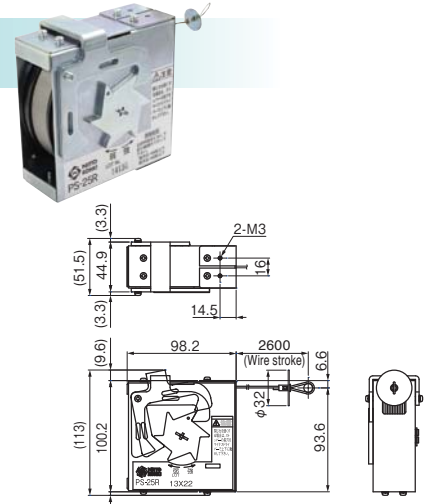
Shaft: Steel
Case: die-cast
Clutch gear: Polyacetal

Control device bracket (for 250kg)



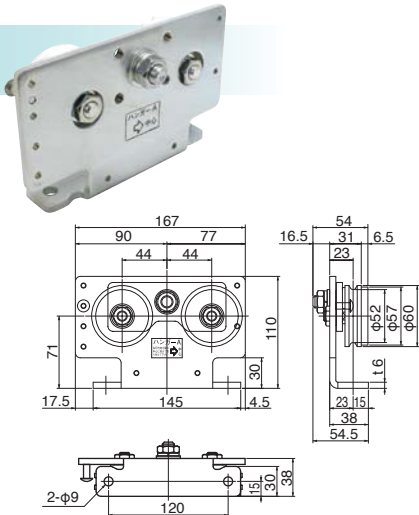
Bracket: Steel
Link gear: Resin

Pull spring (PS-25)



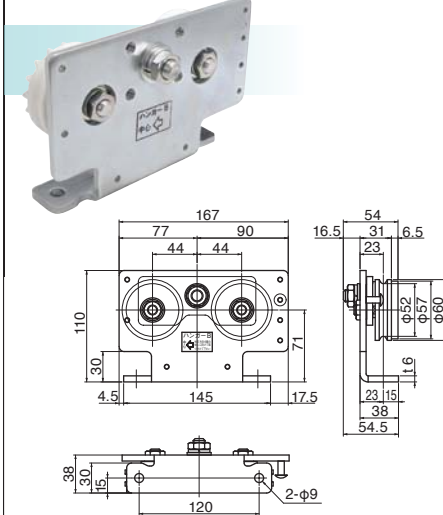
Case: Steel
Spiral spring: Stainless steel

Hanger A (for 250kg)



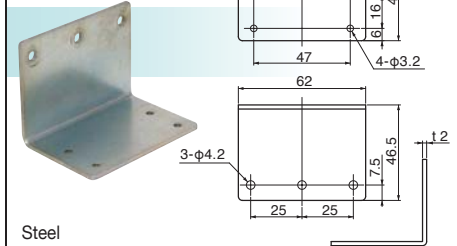
Bracket: Steel
Door roller : Polyacetal

Hanger B (for 250kg)



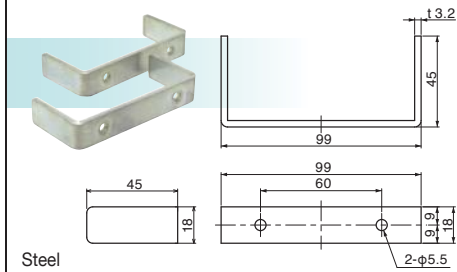
Bracket: Steel
Door roller : Polyacetal

Pull spring bracket (for 250kg)



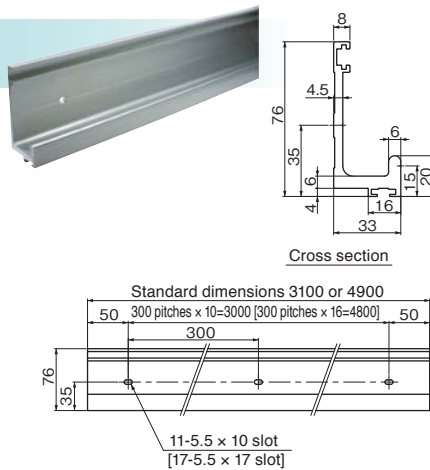
Steel

Door retaining fitting Hanger (for 250kg)



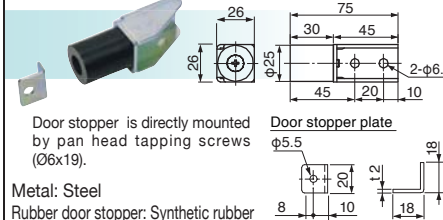
Steel

Rail (for 250kg)



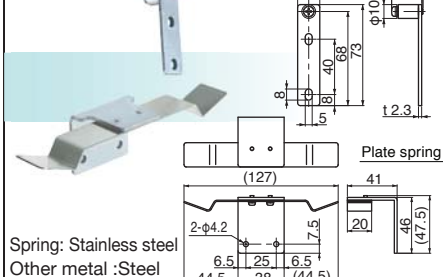
Rail: Aluminum profile (anodized)
*The cross section view is enlarged.

Door stopper (for heavy doors)



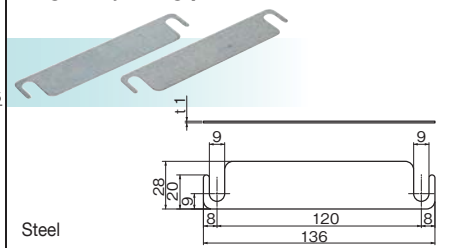
Metal: Steel
Rubber door stopper: Synthetic rubber

Stop device (for 250kg)



Spring: Stainless steel
Other metal :Steel

Height adjusting plate



Steel

Guide roller (Option)

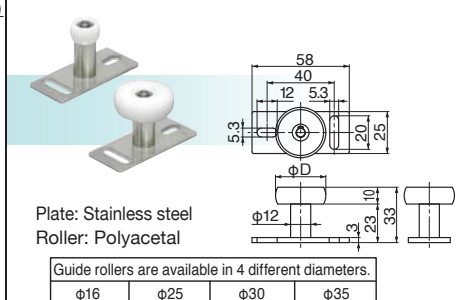
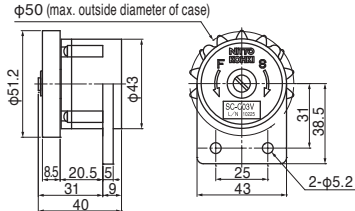
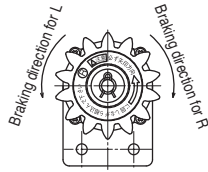


Plate: Stainless steel
Roller: Polyacetal

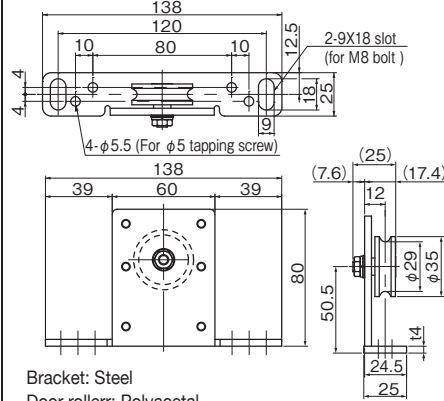
Guide rollers are available in 4 different diameters.
φ16 φ25 φ30 φ35

Control device (SC-C03V, SC-C06V)



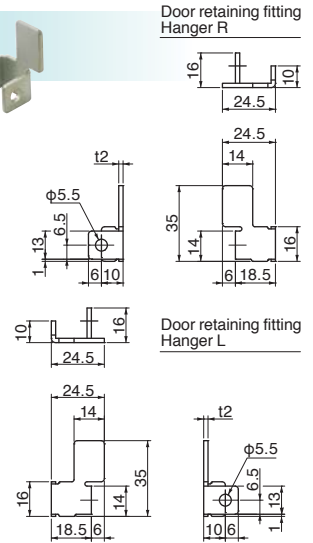
Shaft: Steel
Case: die-cast
Clutch gear: Polyacetal

Hanger



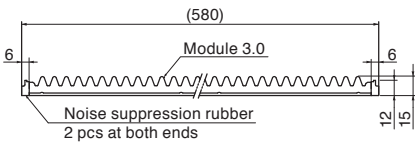
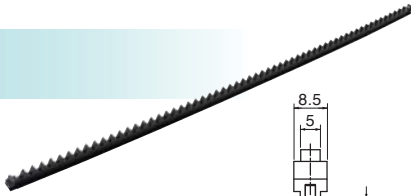
Bracket: Steel
Door rollerr: Polyacetal

Door retaining Fitting



Steel

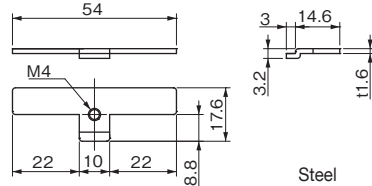
Control rack



*Control rack+noise suppression rubber combined

Control rack: Nylon
*The cross section view is enlarged.
Noise suppression rubber: Synthetic rubber

Control rack fitting

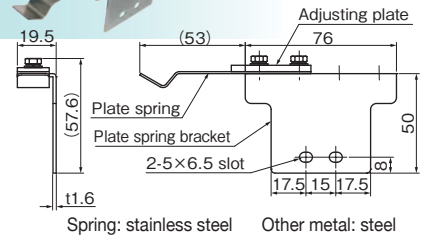


Steel

Stop device (for CV/CWV series)

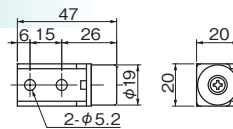


*Plate spring bracket/plate spring/adjusting plate to be assembled in the field.



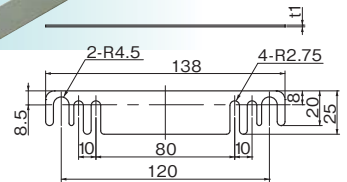
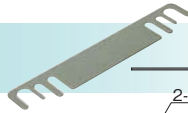
Spring: stainless steel Other metal: steel

Door stopper (for CV/CWV series)



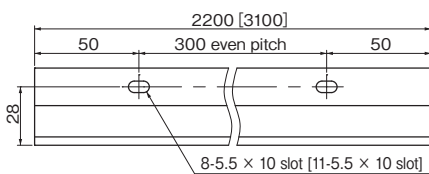
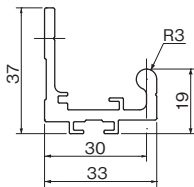
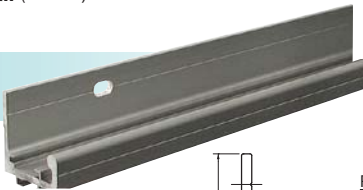
Bracket: Steel
Rubber door stopper: Synthetic rubber

Height adjusting plate



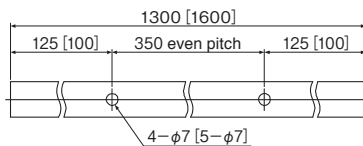
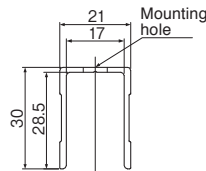
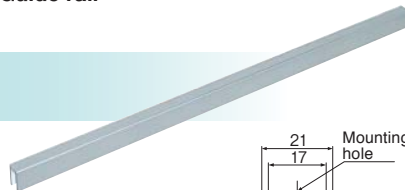
Steel

Rail (for CV)



Aluminum profile (anodized)
*The cross section view is enlarged.

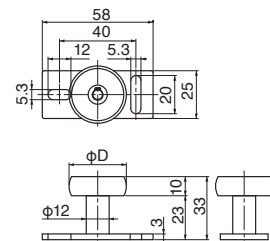
Guide rail



Aluminum profile (anodized)
*The cross section view is enlarged.

Guide roller

Standard set : CWV/CWKS series
Option: CV/CKSV series



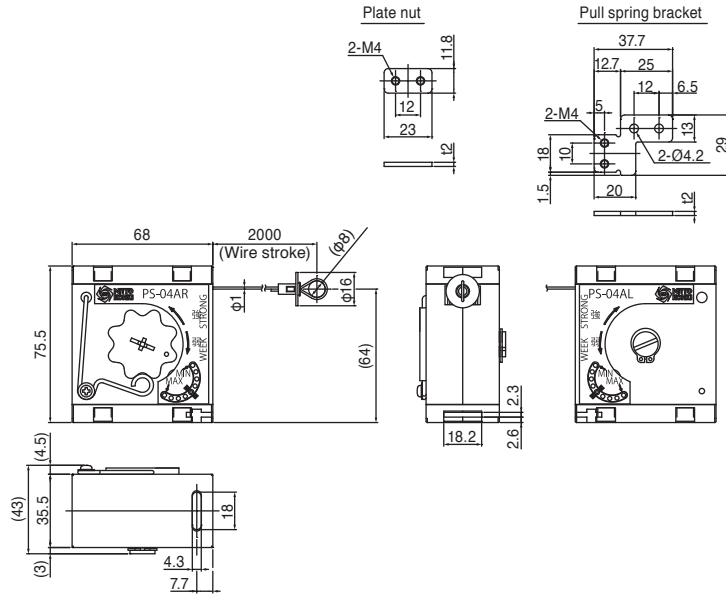
Guide rollers are available in 4 different diameters.
φ16 φ25 φ30 φ35

Plate: Stainless steel
Roller: Polyacetal

Pull spring (PS-04A-CV)



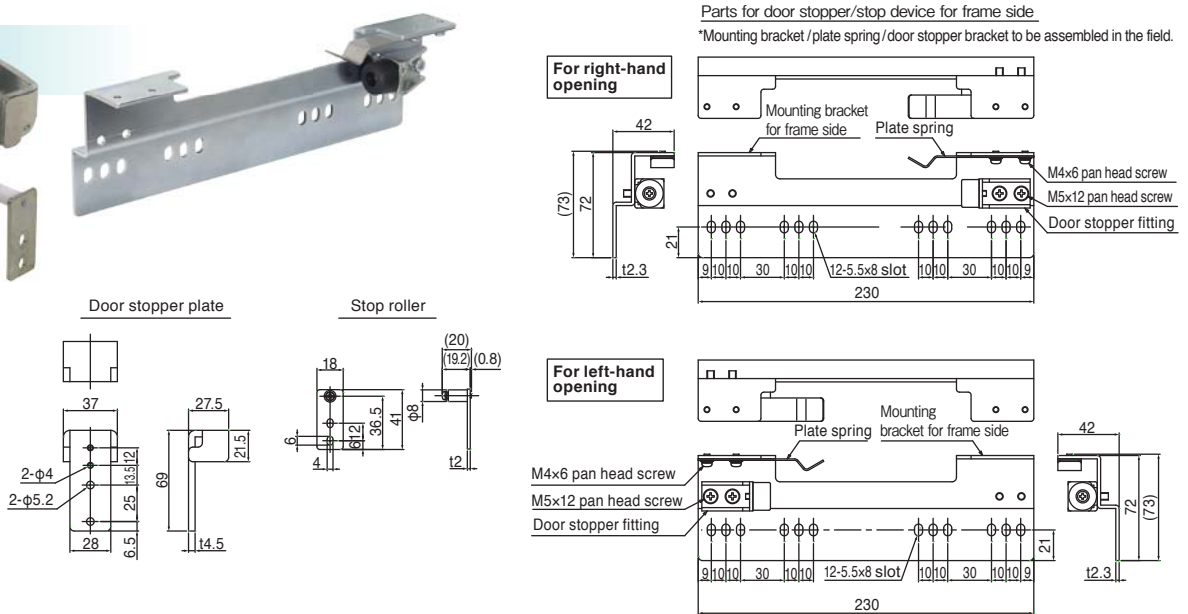
Case: ABS
 Shaft: Zinc die-cast
 Spiral spring: Stainless steel
 Mounting bracket: Stainless steel



Door stopper/Stop device (for CKSV/CWKS series)



Plate spring: Stainless steel
 Door stopper rubber: Synthetic rubber
 Other Metal fittings: Steel



User-friendly technology AUTO HINGE

OTHER RELATED PRODUCTS

FLAG TYPE

- Door closer + hinge, All-In-One. Designed with cutting edge technology from Nitto Kohki. Easy to install on all kinds of swing doors (regular rectangle doors, arch doors, etc).

- Variety of models available for different size and type of doors (wooden, aluminum, lightweight steel, steel and glass doors).



PC series

- Drip-proof design, suitable for outdoor use or moist area.
- Adopts an actuator with unique temperature sensor, ensuring consistent closing speed all year round.



700 series

- Made in highly durable stainless steel with special sealing mechanism.
- Commercial grade, widely applicable for various locations including bathrooms, seashores etc.



BUTTERFLY TYPE

- Small and slim, ideal for lightweight doors (indoor use).
- The butterfly design makes installation highly efficient.
- Non handed - Can be used for both right and left hand opening doors.



CENTER HANG TYPE

- Concealed design, built into the door. Offers clean appearance to the door.
- Suitable for fire doors, smoke ventilations, air intake doors or regular swing doors.



DISTRIBUTED BY



KENWA Trading Corp.

380 N Broadway Suite 302
JERICHO, NY 11753 U.S.A.
P : +1-516-933-6016
F : +1-516-933-6018
E : ktc@kenwa.net



This catalog is printed with vegetable oil inks, using natural energy from wind power generation.

Focused on you

NITTO KOHKI CO., LTD.

Head Office:

9-4, Nakaikagami 2-chome, Ohta-ku, Tokyo 146-8555, Japan
Tel : +81-3-3755-1111 Fax : +81-3-3753-8791
E-mail : overseas@nitto-kohki.co.jp

Overseas Auto Hinge Sales Division:

8F, Orix Ueno bldg., 7-4-7 Ueno, Taito-ku, Tokyo 110-0005, Japan
Tel : +81-3-5806-1030 Fax : +81-3-3843-5188
E-mail : Kentokyo@nitto-kohki.co.jp

Web www.nitto-kohki.co.jp/e



JQA-2025
JQA-EM4057
H.Q./R&D Lab



Open to new possibilities

KENWA Trading Corporation
380 N Broadway Suite 302
Jericho, NY 11753 U.S.A.
P: 1-516-933-6016 F: 1-516-933-6018 E: ktc@kenwa.net



<http://kenwa-america.com/>