

Contents:

<p><b>(A)</b></p> <p><b>Glass Clamp</b></p> <p>(Different type/QTY of glass clamps are supplied based on door width.)</p>	<p><b>(B)</b></p> <p><b>Clamp Fasteners</b></p> <p>200mm clamp: 3 pcs 300mm clamp: 4 pcs 400mm clamp: 5 pcs</p>	<p><b>(C)</b></p> <p><b>Aluminum Frame</b></p> <p>1 pc per door</p>
<p><b>(D)</b></p> <p>ⓓ -1. ⓓ -2.</p> <p><b>Hanger Bracket</b></p> <p>4 pcs per door</p>	<p><b>(E)</b></p> <p>ⓔ -1. ⓔ -2.</p> <p><b>Anti-slide Bracket</b></p> <p>200mm clamp: 1 pc 300mm clamp: 2 pcs 400mm clamp: 2 pcs</p>	<p><b>(F)</b></p> <p><b>Cover</b></p> <p>2 pcs per door</p>

Installation:

- Place the Glass Clamp(s) (A) on the glass door. Then, tighten the clamp(s) with the Clamp Fasteners (B).

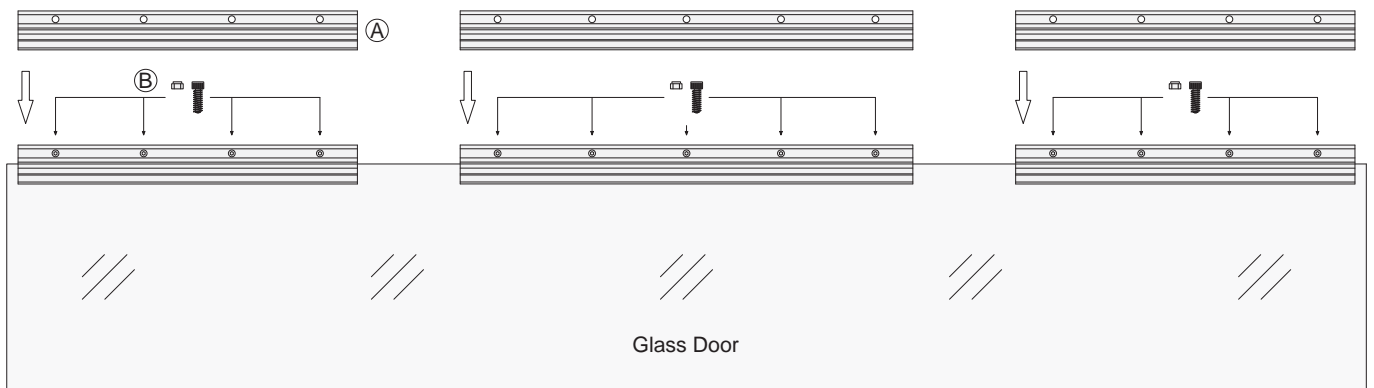
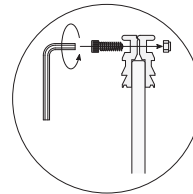

\* Clamp Location:

- Keep 5mm (13/64") gap from edge of glass.
- Keep distance b/w clamps within 105mm (4-9/64") or less.

(See the following examples.)

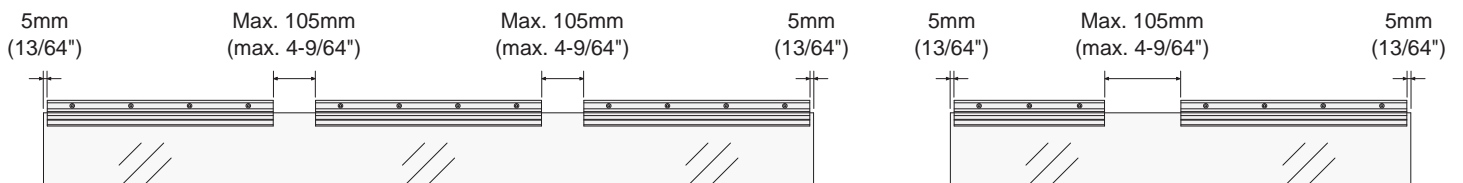

Installation (continued):

2. Cut the Aluminum Frame (C) to the length of door width less 10mm (25/64").

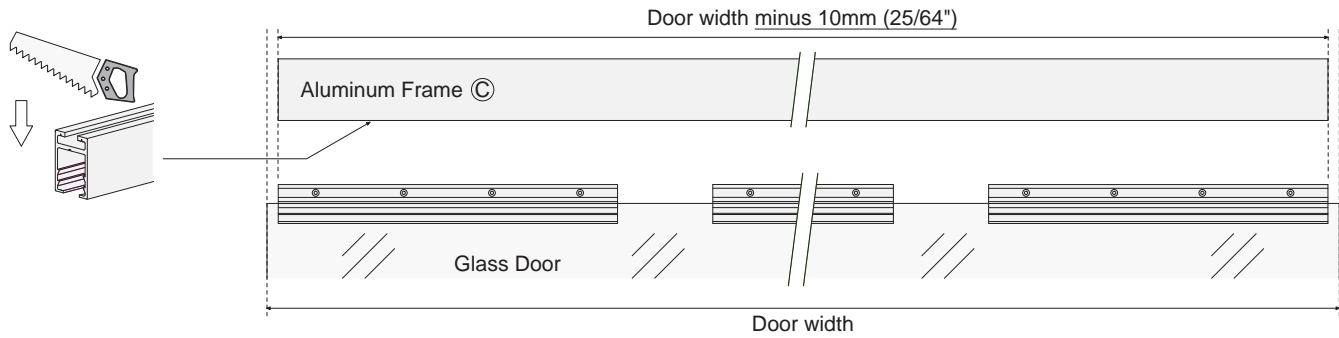

3. Drill Ø8mm (Ø5/16") holes inside the top channel of Aluminum Frame (C) at 20mm (3/4") position from each edge of glass clamps.

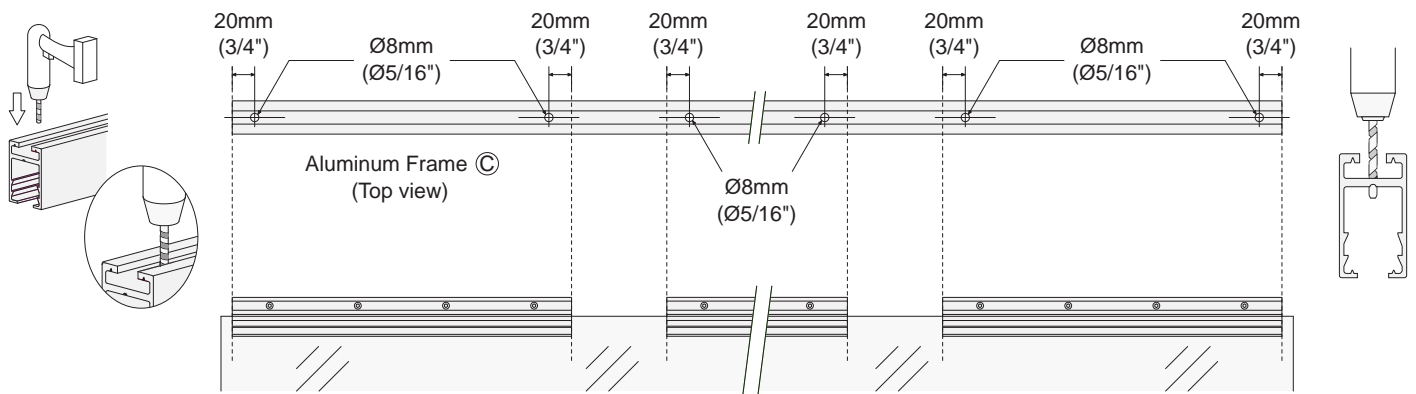

(For 200mm clamp, drill only one hole at one side.)

4. Slide the Aluminum Frame (C) over the glass clamps.

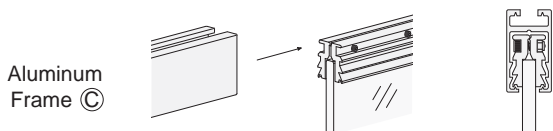

7. Lock the Anti-slide Bracket (E)-1. with the screw (E)-2. through the Ø8mm holes (--> See section 3.)

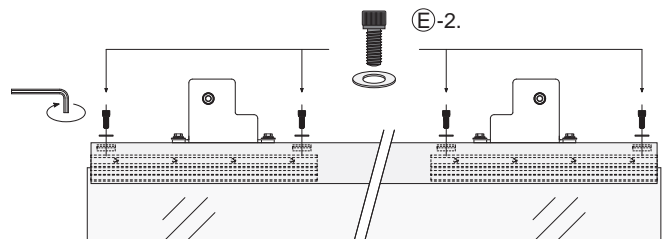

- 300mm/400mm clamp : (2) brackets per clamp.
- 200mm clamp : (1) bracket per clamp.

5. Insert the Hanger Bracket (D)-1. and the Anti-slide Bracket (E)-1. into the top channel of aluminum frame.

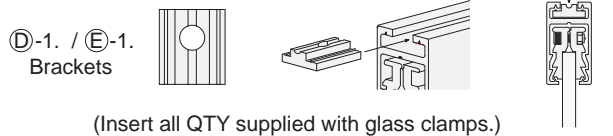

6. Attach your door hangers to the Hanger Bracket (D)-1. with the screw (D)-2.

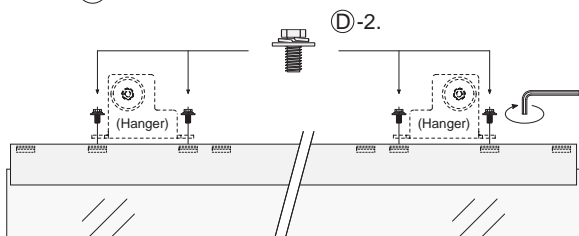

8. Place the Cover (F) on both ends.

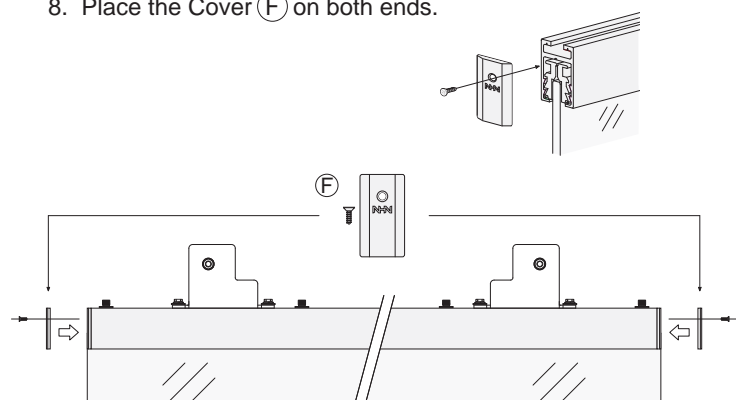

# Sliding Glass Door Closer - System Diagram



## NSC-C60V-G series (up to 60 kgs / 132 lbs doors)

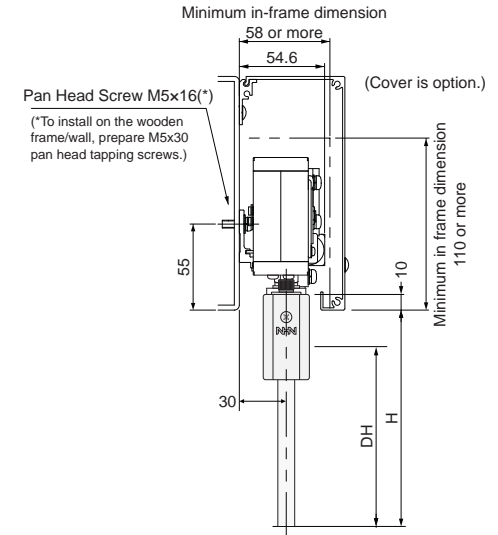
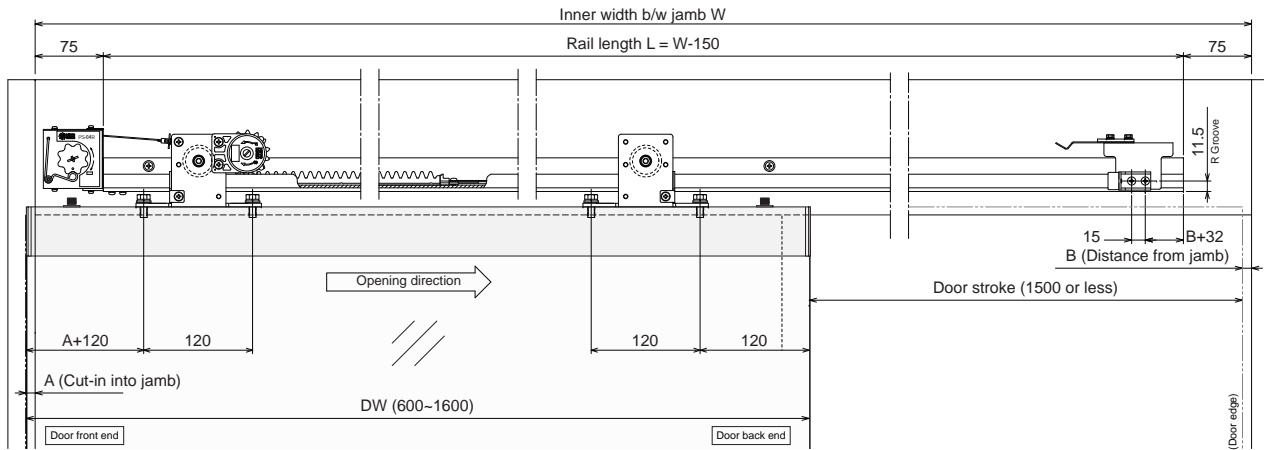

## NSC-C48-G series (up to 80 kgs / 176 lbs doors)

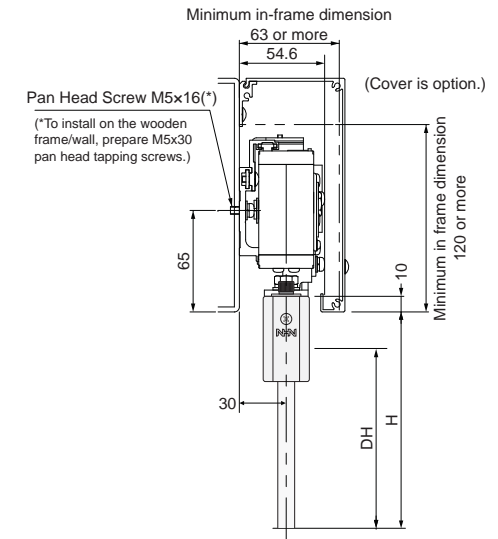
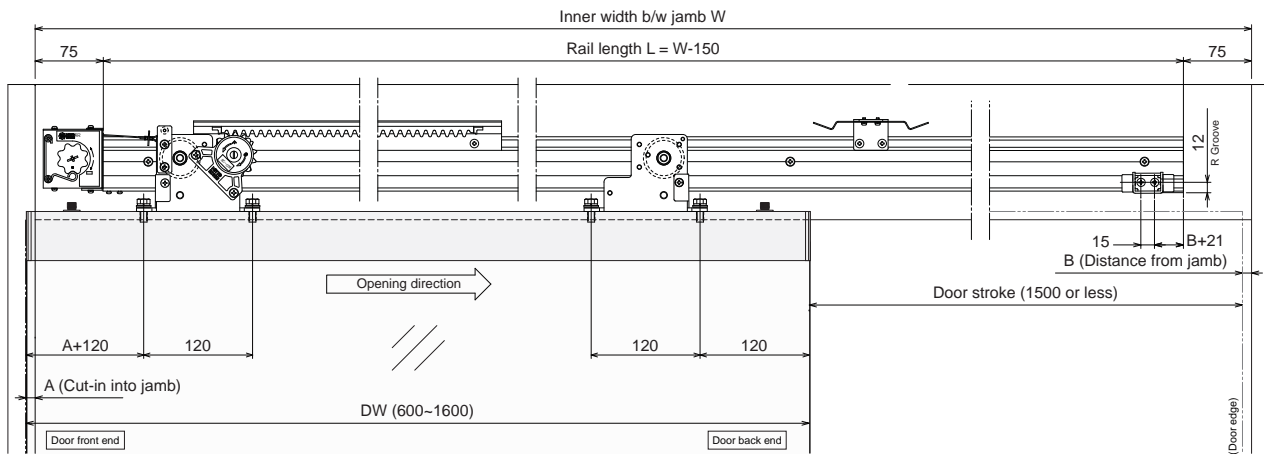

# Sliding Glass Door Closer - System Diagram



## NSC-C1215-G series (up to 150 kgs / 330 lbs doors)

